

Instruction Manual

CVS Series E 1 through 6-Inch Globe Valves

Design “ED” and “ET”

Introduction

Contents

Contained in this manual are installation instructions, maintenance procedures and parts information for the 1 through 6-inch CVS Series E, Design ED and ET Globe Valves. Refer to the appropriate manuals for instructions for the accompanying actuator and additional accessories.

Trained or experienced personnel should carry out operation and installation of all pressure equipment. If you have any questions regarding the equipment, contact your CVS Controls representative.

Applications and Features

The CVS Series E is a single port, globe-style body with composition or metal seats and a balanced push-down-to-close valve action plug.

There are two styles of valve available, providing excellent pressure and flow control on steam, gasses and various liquid applications:

1. **Design ED** is intended for general control applications over a wide variety of temperatures and pressure drops. This design has an upper piston ring seal and metal-to-metal seating.
2. **Design ET** is intended for applications requiring low leakage rates with composition seating (TFE) for tight shutoff requirements or metal-to-metal seating for higher temperature capabilities. The valve plug has a two-piece upper seal.



Figure 1: CVS Series E Valve

For standard cages the flow direction is flow-down. The following flow characteristics are available: linear, quick opening and equal percent.

The end connections are ANSI Class 150, 300 and 600 Raised Face, or Ring Type Joint flanges as per ASME B16.34-latest edition.

CVS Series E Globe Valve are available in the following body materials - LCC, WCB, WCC, WC9, C5, Monel, and CF8M SST. Additional materials may be available upon request.

Trim material is available in 316SST, 416SST, 17-4PH, Alloy6-Co.Cr-A, Cobalt and 316SST/Tungsten Carbide.

Sour Service Capability

Optional NACE MRO175/ISO 15156-2009

Head Office
3900 – 101 Street
Edmonton, Alberta, Canada T6E 0A5
Office: (780) 437-3055
Fax: (780) 436-5461

CVS
CONTROLS

Calgary Sales Office
3516 114 Avenue SE
Calgary, Alberta, Canada T2Z 3V6
Office: (403) 250-1416
Fax: (403) 291-9487

Website: www.cvs-controls.com E-Mail: info@cvs-controls.com

Installation

1. Before installing a CVS Series E valve carefully inspect for damage that may have occurred in shipment.
2. Remove all welding slag, pipe scale and any other foreign matter by cleaning out the lines before installation.
3. Install the valve so that the flow direction arrow on the body coincides with the actual process flow through the valve.
4. Use accepted piping practices when installing the valve. Use a suitable gasket between pipeline flanges and valve body.
5. Although the control valve can be installed in any position, the typical installation has the actuator vertical above the body.
6. Installing a conventional 3-valve bypass around the body will allow for continuous operation during maintenance and inspection.
7. CVS Series E valve bodies are rated at 150, 300 and 600 lb. ANSI. Be sure not to install the valve in any system where working pressures are greater than those specified in the standards.

Valve Size, Inches	Weight	
	Lbs	Kg
1, 1-1/4	30	14
1-1/2	45	20
2	68	31
2-1/2	100	45
3	125	57
4	170	78
6	350	160

Table 1: Approximate Weights

Maintenance

Warning:

To avoid damage to the process system or personal injury, isolate the valve from the system and relieve any pressure contained within prior to disassembly. Disconnect any operating lines providing air pressure, control signals or electrical power to the actuator.

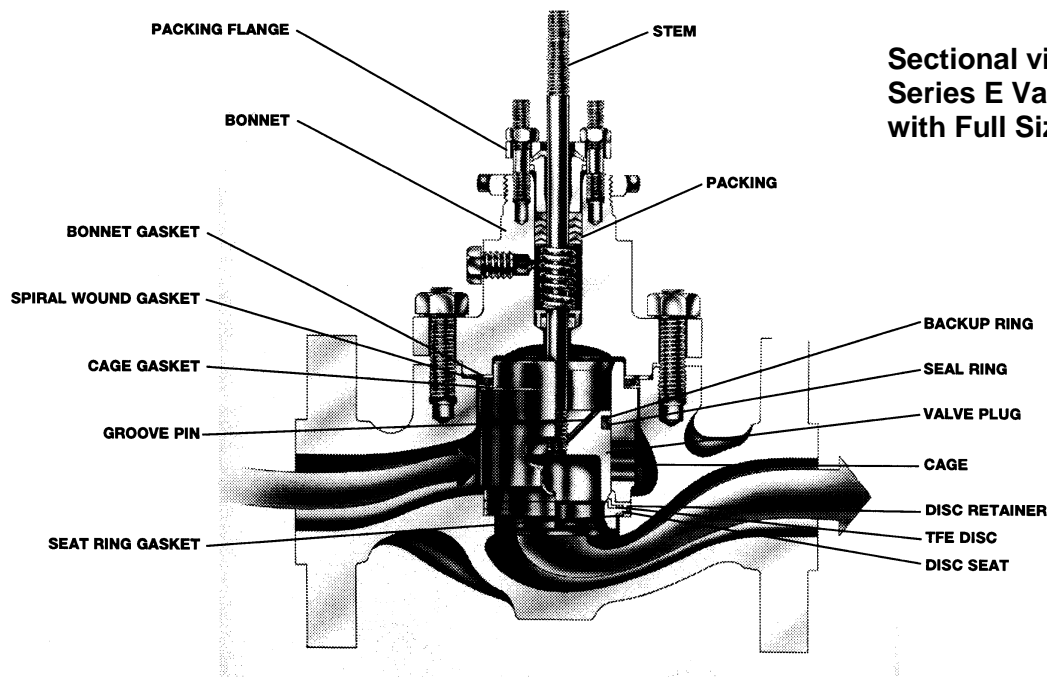

Figure 2:

Sectional view of CVS Series E Valve Body with Full Size Trim

Disassembly

Except where indicated, refer to Figure 2 for part descriptions used in the following procedure.

1. With the actuator disconnected and removed from the body, remove the hex nuts, (key 15, figure 9).
2. Remove the bonnet with the valve plug and stem.
3. Loosen the packing flange nuts (key 5, figure 8) and remove the valve plug and stem from the bonnet. If the valve stem needs replacement, punch out the groove pin and unscrew the stem. If the valve plug needs replacement, a new valve plug and stem assembly is required.

Warning: Do not use an old stem with a new valve plug. Using an old stem requires drilling a new hole for the groove pin and as a result, the integrity of the stem is weakened.

4. If desired you may disassemble the internal parts of the bonnet. To replace the Packing, see instructions titled "Packing Replacement" in this manual.

Warning: The portion of the cage which is exposed provides a guiding surface. Ensure that this surface is not damaged during disassembly or maintenance. If the cage is seized in the body, use a rubber mallet to strike the exposed portion at varying points around its circumference.

5. Remove the cage and gaskets from the valve body. With restricted trim, (figure 11) remove the seat ring adaptor (key 5) and the cage adaptor (key 4).
6. Remove the seat ring and its gasket. With composition seats, remove the disc retainer, disc seat and TFE disc.

Reassembly

Except where indicated refer to Figure 2 for part descriptions used in the following procedure.

1. Clean all gasket-seating surfaces. Use new gaskets only for reassembly.
2. With restricted trim (figure 11) install the seat ring adaptor gasket (key 13) and the adaptor (key 5).
3. Replace the seat ring gasket (key 12) and install the seat ring (key 8). If using a composition seat, assemble it by placing the TFE disc (key 20) into the disc retainer (key 18), then sliding this assembly over the disc seat (key 19).



Figure 3: Equal Percentage Cage

4. Place the cage (key 3) onto the seat ring (key 9). Any rotational orientation of the cage with respect to the valve body is acceptable.
5. With full-sized trim, install cage gasket (key 10), spiral wound gasket (key 11) and bonnet gasket (key 9) onto the cage shoulder.
6. With restricted trim, install the cage gasket (key 10), spiral wound gasket (key 11) and an additional cage gasket (key 10) onto the cage shoulder. Install the cage adaptor and place the bonnet gasket onto the adaptor.
7. If installing a new stem in the valve plug, screw the new stem into the valve plug. Refer to Table 2 for appropriate torque values and drill sizes. Drill through the stem, using the hole in the valve plug as a guide. Remove any chips or burrs and drive in a new groove pin to lock the assembly.
8. If the seal ring appears damaged, remove and replace with a new one. Be careful not to scratch the ring groove surfaces. Damage to the ring groove surface may prevent the new ring from sealing properly. The seal ring must either be pried or cut from the groove and therefore cannot be reused.

If possible, lapping of metal seats should be done before seal ring installation. Refer to the "Lapping Metal Seats" procedure in this manual.

- 8a For valve bodies using a carbon-filled TFE piston ring, locate the split and slightly spread the ring. Install the ring over the stem and onto the piston ring groove on the valve plug. Graphite piston rings are supplied as a complete ring and must be broken into two sections. The piston ring can be broken in half by scoring, and then breaking over a hard surface such as the edge of a table. Ensure the broken ends are re-matched when the piston ring is installed in the piston ring groove.

Reassembly cont'd

8b Apply a lubricant to both back-up ring and seal rings. Install the back-up ring over the stem and into the piston ring groove. Place the seal ring over the top edge of the valve plug, so that it slips into the groove on one side of the valve plug.

Cautiously stretch the seal ring to work it over the top edge of the valve plug. Avoid jerking sharply on the seal, as the TFE in the seal ring needs time to cold flow during the stretching procedure. This stretching may make the seal ring seem loose in the groove; however it will contract to its original size after installation of the cage.

9. When placing the valve plug into the cage, ensure that the seal ring is evenly set in the entrance bevel at the top of the cage to avoid ring damage.
10. Mount bonnet to the body.
11. Tighten the bonnet to body bolts. Refer to Table 3 for recommended torques.

Always adhere to accepted bolting practices and lubricate bolts. Correct tightening of the bonnet bolts accomplishes the following:

- a) The spiral wound gasket will compress enough to load and seal the seat ring gasket.
- b) The outer portion of the top gasket will compress so that the bonnet to body connection forms a seal.

Note: Bolt up characteristics for spiral wound gaskets are such that the tightening of one bolt may loosen another. This will occur with the tightening of all the bolts until the bonnet to body seal is made. Several trials on each bolt are required until, at the given torque, the nut does not turn.

12. Mount the actuator to the bonnet and make up the stem connection. Refer to "Making up Stem Connection" instructions in this manual.

Table 2: Stem Torque and Groove Pin Drill Sizes

Valve Stem Connection (VSC)		Torque Min/Max Values		Groove Pin Drill Size
Inches	Mm	Lbf-Ft	N-m	Inches
3/8	9.5	40-47	25-35	3/32
1/2	12.7	81-115	60-85	1/8
3/4	19.1	237-339	175-25-	3/16
1	25.4	420-481	310-355	1/4
1-1/4	31.8	827-908	610-670	1/4

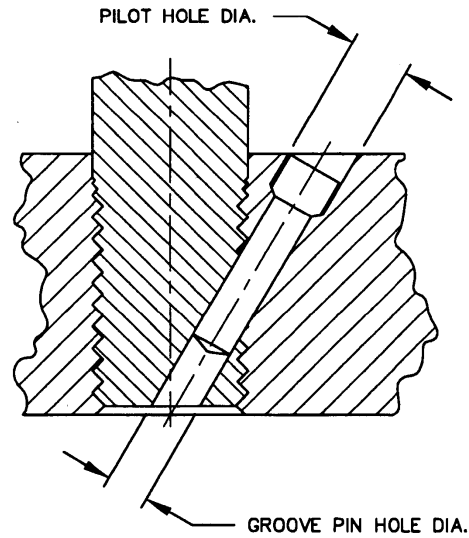

Table 3: Body to Bonnet Bolt Torques

Valve Size Inches	Bolt Torques SA 193-B7	
	Lbf-Ft	N-m
1-1/4 or less	95	133
1-1/2, 1-1/2x1m, 2, 2x1	71	100
2-1/2, 2-1/2x1-1/2	95	133
3, 3x2, 3x2-1/2	125	175
4, 4x2-1/2, 4x3	200	280
6	405	567

Packing Maintenance

TFE V-Ring Packing

Except where indicated, refer to Figure 8 for part descriptions used in the following procedure.

1. For spring loaded single TFE V-ring packing, the spring (key 8) maintains the sealing force on the packing. If leakage is detected around the packing follower (key 13), tighten the packing flange nuts (key 5) until the leakage stops. If the shoulder of the packing box is touching the bonnet and leakage cannot be controlled in this manner, see "Packing Replacement".

Packing Replacement

1. Once the actuator and bonnet have been separated from the body (refer to Steps 1-2 of Disassembly procedure), remove the following from the bonnet:
 - a. Packing flange nuts (key 5)
 - b. Packing flange (key 3)
 - c. Felt wiper (key 12)
 - d. Packing follower (key 13)

Packing Replacement cont'd

2. Clean the packing box bore, spring (key 8), washer (key 10), and the packing box ring (key 11).
3. Install the valve plug assembly and mount the bonnet to the body using new gaskets. Use the sequence shown in Figure 4 to install new packing and associated parts. Be sure not to damage the packing during installation. Replace the packing flange (key 3), tighten the packing flange nuts (key 5) until the shoulder of the packing follower (key 13) is approximately 5/8" from the top of the bonnet. If leakage is detected around the packing follower, tighten the packing flange nuts until the leakage stops.
4. For graphite packing, tighten the packing flange nuts to the maximum torque value in Table 4. Then back off the nuts and retighten them to the minimum torque value in Table 4.
5. For other Packing Types, in small equal increments, tighten the flange nuts until one of the nuts reach the minimum torque shown in Table 4. Then, tighten the other nut until the packing flange is level.
6. Mount the actuator and set the stem connector to the required travel. Refer to "Making Up Stem Connection" procedure.

Packing Lubrication

The use of semi-metallic packing requires the use of a lubricator or lubricator/isolating valve (figure 5). The lubricator or lubricator/isolating valve is mounted in place of a pipe plug (key 14, figure 7, 8). For standard service up to 450°F, use Dow Corning lubricant or equivalent.

Lubricator: To add lubricant to the packing box, turn the cap screw in a clockwise direction.

Lubricator/Isolating Valve: Open the isolating valve, turn the cap screw in a clockwise direction, then close the isolating valve.

Lapping Metal Seats

In any valve body, a certain amount of leakage should be expected with metal-to-metal seating. However, if the leakage becomes excessive, lapping can enhance the condition of the seating surfaces of the valve plug and seat ring. Deep nicks in the seating surface should be removed by machining rather than lapping. There are many lapping compounds available commercially. Be sure to use one of high quality. Apply lapping compound to the bottom of the plug.

In order to position the cage and seat ring properly and to help align the valve plug with the seat ring, bolt the bonnet to the body with gaskets (the old gaskets can be used) in place during the lapping procedure. A simple handle can be made from a piece of metal secured to the valve stem with nuts. Rotate the handle in opposite directions to lap the seating surfaces. Once lapping is complete, disconnect the bonnet, clean the seating surfaces, reassemble and then test for shutoff. If leakage is still excessive, repeat the lapping procedure.

Table 4: Torque Values for Packing Flange Nuts

Valve Stem Diameter		ANSI Rating	PTFE Type Packing				Graphite Type Packing			
Inches	Mm		Min. Torque		Max. Torque		Min. Torque		Max. Torque	
			Lbf-in	N-m	Lbf-in	N-m	Lbf-in	N-m	Lbf-in	N-m
3/8	9.5	150	13	1	19	2	27	3	40	5
		300	17	2	26	3	36	4	53	6
		600	23	3	35	4	49	6	73	8
1/2	12.7	150	21	2	31	4	44	5	66	8
		300	28	3	42	5	59	7	88	10
		600	39	4	58	7	81	9	122	14
3/4	19.1	150	47	5	70	8	99	11	149	17
		300	64	7	95	11	133	15	199	23
		600	87	10	131	15	182	21	274	31
1	25.4	300	108	12	162	18	226	26	339	38
		600	149	17	223	25	310	35	466	53
1-1/4	31.8	300	152	17	228	26	318	36	477	54
		600	209	24	314	36	437	49	655	74

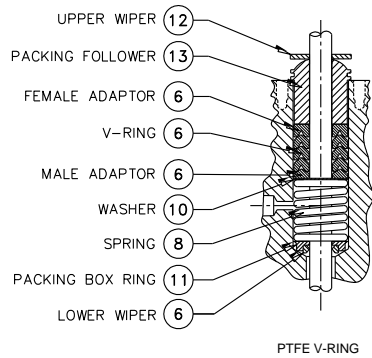

PTFE V-RING

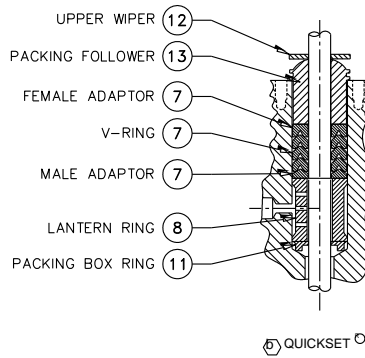

QUICKSET

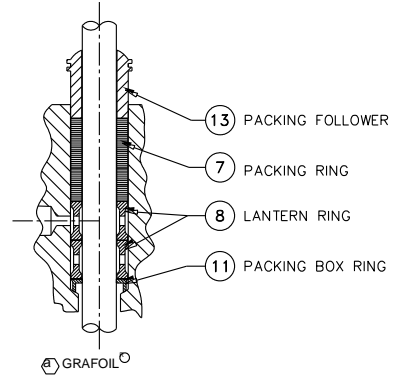

GRAFOIL

SINGLE PACKING
ALL YOKE SIZES

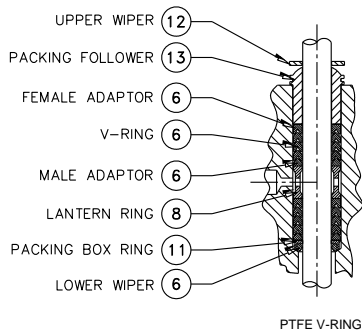

PTFE V-RING

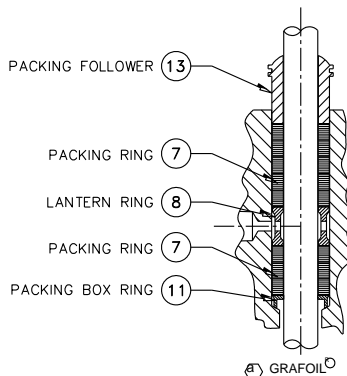

GRAFOIL

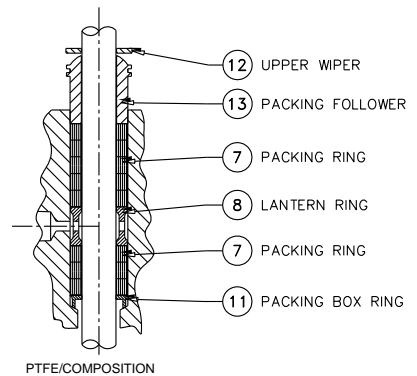

PTFE/COMPOSITION

DOUBLE PACKING
ALL YOKE SIZES

NOTES:

- GRAFOIL IS A REGISTERED TRADEMARK OF UNION CARBIDE
- QUICKSET IS A REGISTERED TRADEMARK OF GARLOCK INC.

Figure 4 - Packing Arrangements-See Table 4 for recommended torque values.

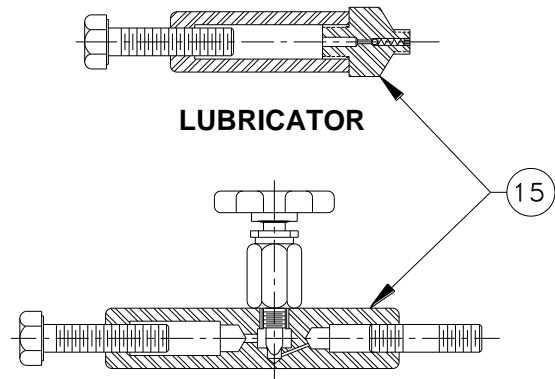

LUBRICATOR/ISOLATING VALVE

Figure 5 - LUBRICATOR AND LUBRICATOR/ISOLATING VALVE

Making Up Stem Connection

Direct Acting Actuator

Refer to Figure 6 for part descriptions used in the following procedure.

1. Move the valve plug to the closed position.
2. Thread stem locknuts onto the stem and set the travel indicator disc on these nuts. The cupped portion of the indicator disc should face downward.
3. Move the valve plug stem up the required travel and attach the stem connector. Make sure there is full engagement of the actuator stem threads. Place the two cap screws in the stem connector and tighten only slightly at this time. Position the travel indicator disc against the bottom of the stem connector by tightening the stem lock nuts slightly.
4. The travel indicator should indicate the valve to be wide open with no pressure on the diaphragm. If it does not, loosen the screws that hold the travel indicator scale and move the scale to the position required.
5. Apply varying pressures to the diaphragm case and observe the valve travel. Make certain that the valve plug seats on the seat ring.

Note: If the travel is not correct on units with plain or extension bonnets, the travel can be corrected by screwing the valve plug stem either into or out of the stem connector. Always use a wrench on the lock nuts to turn the stem. Do not use pliers or a pipe wrench directly on the stem itself. Make sure not to turn the valve plug while it is on the seat.

Reverse Acting Actuator

Refer to Figure 6 for part descriptions used in the following procedure.

1. Move the valve plug to closed position.
2. Thread stem locknuts onto stem then set the travel indicator disc on these nuts. The cupped portion of the indicator disc should face downward.
3. Move the valve plug stem up the required travel and attach the stem connector. Make sure there is full engagement of the actuator stem threads. Place the two cap screws in the stem connector and tighten only slightly at this time. Position the travel indicator disc against the bottom of the stem connector by tightening the stem lock nuts slightly.
4. The travel indicator should indicate the valve to be wide open with non pressure on the

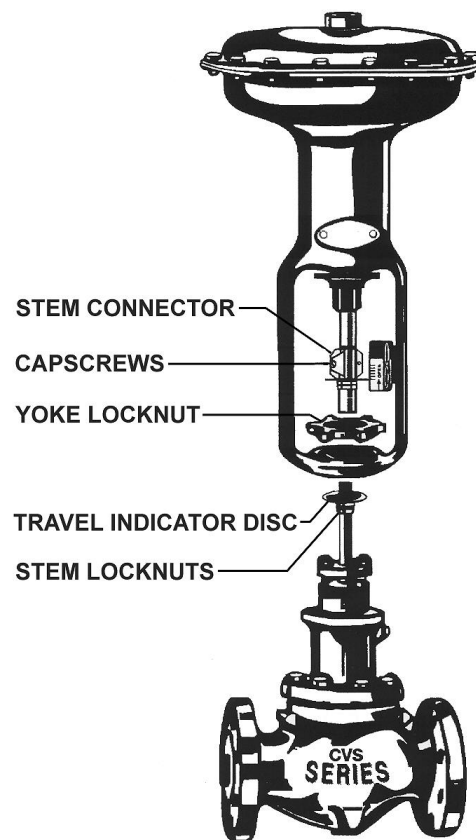

Figure 6: Actuator Mounting

diaphragm. If it does not, loosen the screws that hold the travel indicator scale and move the scale to the required position.

5. Apply varying pressures to the diaphragm case and observe the valve travel. Make certain that the valve plug seats on the seat ring.

Note: If the travel is not correct on units with plain or extension bonnets, the travel can be corrected by screwing the valve plug stem either into or out of the stem connector. Always use a wrench on the lock nuts to turn the stem. Do not use pliers or a pipe wrench directly on the stem itself. Make sure not to turn the valve plug while it is on the seat.

Parts Ordering

A serial number identifies every CVS Series E valve body-bonnet assembly, which can be found on the front of the valve. Please refer to this number when contacting your CVS Controls representative.

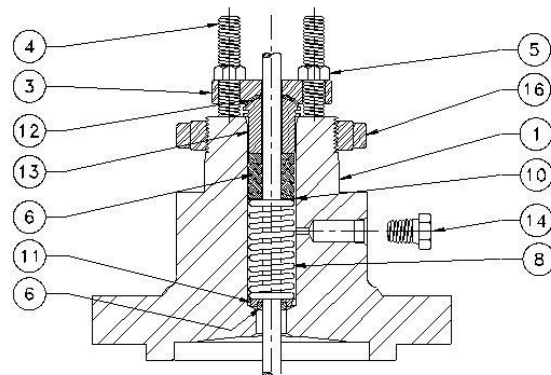
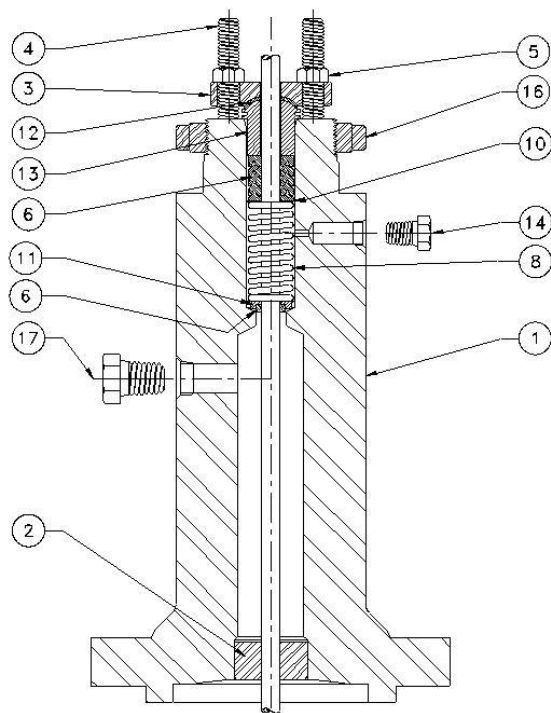

Figure 8: Extension Bonnet

Key	Part Name	Key	Part Name
1	Bonnet	10	Special Washer (TFE Packing Only)
2	Bushing (Extension bonnets only)	11	Packing Box Ring
3	Packing Flange	*12	Upper Wiper
4	Packing Flange Stud	13	Packing Follower
5	Packing Flange Nut	14	Pipe Plug
*6	Packing (TFE V-Ring Packing Only)	15 ¹	Lubricator or Lubricator/Isolating Valve ²
*7 ¹	Packing Ring (Not req'd with TFE Packing)	16	Yoke Locknut (2-1/8, 2-13/16, 3-9/16 Yoke Bosses)
8	Spring / Lantern Ring	17	Pipe Plug
9 ¹	Packing Ring (Not req'd with TFE Packing)	^() Recommended Spare Part ⁽¹⁾ Not Shown ⁽²⁾ See Packing Lubrication	

CVS Series E Parts Reference List

Body

Key	Part Name	Material	Key	Part Name	Material
A1	Valve Body	---	14	Stud	Steel
*2	Plug	316 SS	15	Hex Nut	Steel
3	Cage		16	Flow Direction Arrow	316 SS
4	Cage Adaptor (Except 6/4 Restricted Trim)	17-4 DHT	17	Drive Screw	316 SS
5	Seat Ring Adaptor	316 SS	*18	Disc Retainer (Composition Seat)	316 SS
*6	Stem	316 SS	*19	Disc Seat (Composition Seat)	316 SS
*7	Groove Pin	316 SS	*20	TFE Disc	TFE
*8	Seat Ring (Metal Seat Only)	316 SS	*21	Seal Ring	Carbon Filled TFE
*9	Bonnet Gasket	Graphoil	*22	Back-up Ring	Viton/EPDM
*10	Shim	316 SS			
*11	Spiral Wound Gasket	316 SS Graphoil			
*12	Seat Gasket	Graphoil			

(*) Recommended Spare Parts
(A)-Consult CVS Controls Representative for Valve Body style, size and material availability

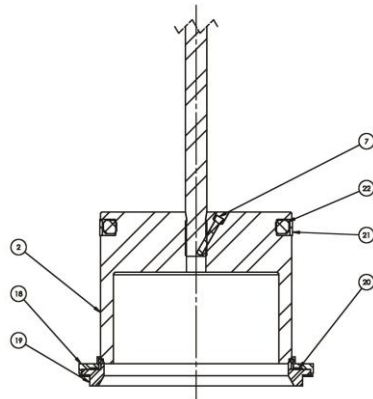
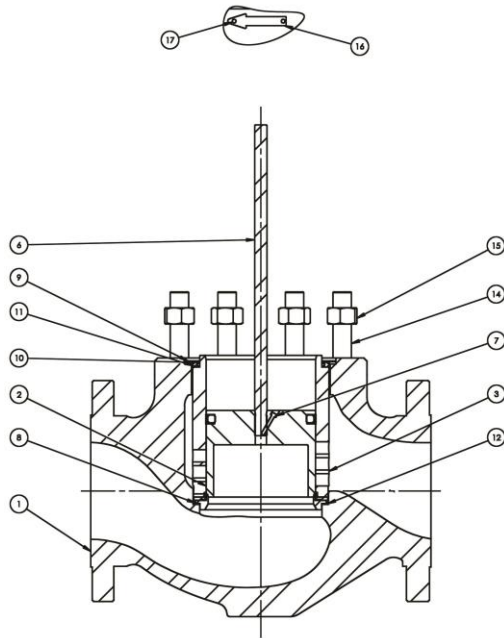

Figure 9: CVS Series E with Full Capacity

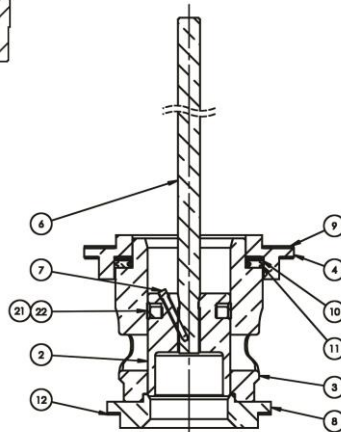

Figure 10: Trim for 1-1/2 x 1 Valve Body

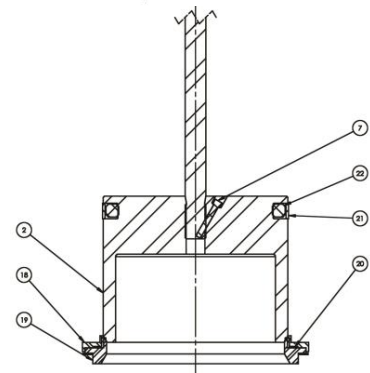
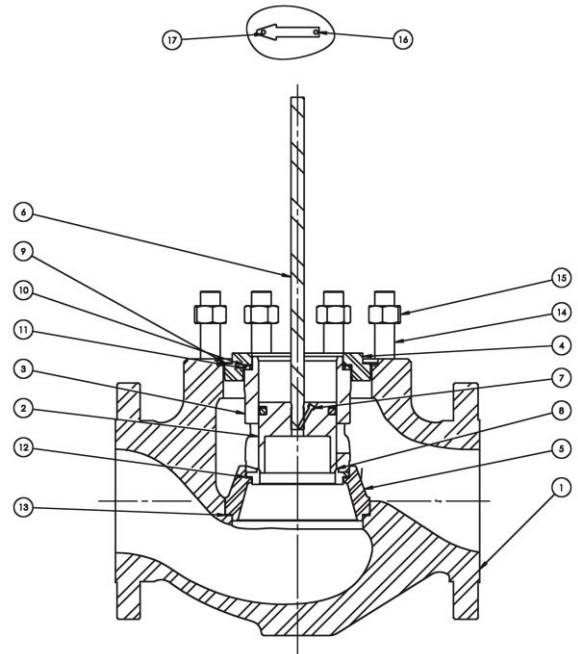

Figure 11: CVS Series E with Restricted Trim

CVS Series E Trim Parts List

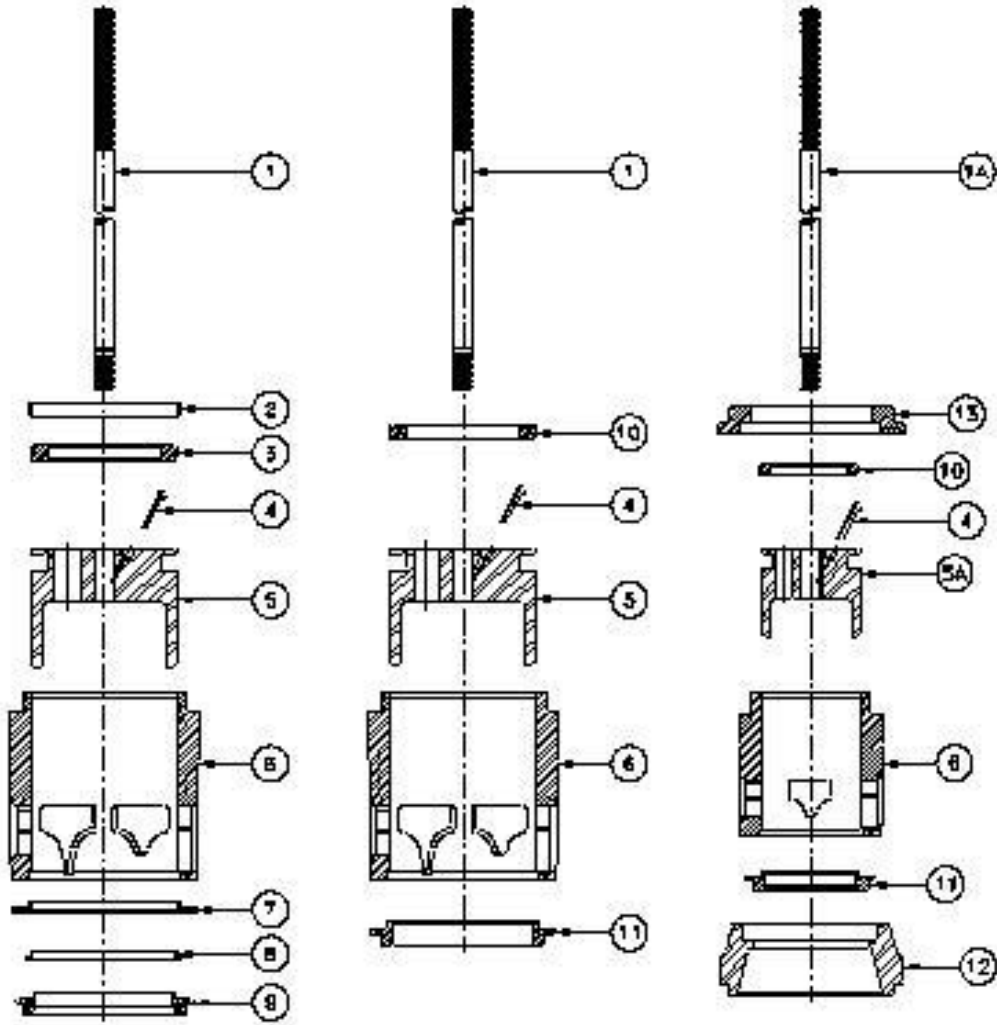

Figure 12: CVS Series E Internal Assemblies – See Following Tables

CVS Series E Trim Parts List

Key 1, 1A, 5 and 5A (Optional Materials Available upon Request*)

"ED" & "ET" Body Size (In)	VSC (In)	Key 4	Key 1	Key 5-Plug		"ET" Body Size (In)	VSC (In)	Key 5A-Plug	
		Groove Pin	Stem	316 SS ^A	416 SS			316 SS ^A	416 SS
1	3/8	CVS1V32263507	CVS1U38883516	CVS1V65713507	CVS1V65714617	1-1/2 x 1	3/8	CVS1V65713507	CVS1V65714617
	1/2	CVS1V32273507	CVS1U38903516	CVS1V65723507	CVS1V65724617	2 x 1	1/2	CVS1V65723507	CVS1V65724617
1-1/2	3/8	CVS1V32253507	CVS1U38883516	CVS1V63733507	CVS1V63734617	2-1/2 x 1-1/2	1/2	CVS1V65743507	CVS1V65744617
	1/2	CVS1V32273507	CVS1U38903516	CVS1V65743507	CVS1V65744617	3 x 2	1/2	CVS1V65753507	CVS1V65754617
2	1/2	CVS1V32263507	CVS1K58693516	CVS1V65753507	CVS1V65754617		3/4	CVS1V65763507	CVS1V65764617
	3/4	CVS1V32603507	CVS1U22653516	CVS1V65763507	CVS1V65764617	4 x 2-1/2	3/4	CVS1V65783507	CVS1V65784617
2-1x2	1/2	CVS1V32263507	CVS1U23053516	CVS1V65773507	CVS1V65774617	6 x 4	3/4	CVS1V65823507	CVS1V65824617
	3/4	CVS1V32603507	CVS1U23083516	CVS1V65783507	CVS1V65784617	"ET" Body Size (In)	VSC (In)	Key 1A	
3	1-2	CVS1V32263507	CVS1U23053516	CVS1V65793507	CVS1V65794617			Stem	
	3/4	CVS1V32273507	CVS1U23053516	CVS1V65803507	CVS1V65804617	1-1/2	3/8	CVS1U22363516	
4	1/2	CVS1V32263507	CVS1U23053516	CVS1V65813507	CVS1V65814617	x 1	1/2	CVS1K58693516	
	3/4	CVS1V32603507	CVS1K58773516	CVS1V65823507	CVS1V65824617	2 x 1	1/2	CVS1U38903516	
6	1	CVS1V33403507	CVS1N70473516	CVS1V65853507	CVS1V65854617	2-1/2 x 1-1/2	1/2	CVS1U38903516	
	1-1/4		CVS1K41543516	CVS1V65863507	CVS1V65864617	3 x 2	1/2	CVS1K58693516	
							3/4	CVS1U22653516	
							4 x 2-1/2	1/2	CVS1U23053516
							3/4	3/4	CVS1U23083516
							6 x 4	3/4	CVS1L99643516

(A) - Not for use with 17-4PH SS Cages above 410°F (210°C); use High Temp Plugs for these applications

* Tungsten Carbide and Cobalt Trim available upon request. Contact a CVS Controls Representative for more information.

Key 2 & 3 Seal Ring and Back-Up Ring

"ET" Body Size (In)	Key 2 Seal Ring	Key 3 Back-Up Ring	
	TFE Carbon Filled	0°F to 400°F Viton (Std)	-65°F to 300°F EPDM
1, 1-1/2x1, 2x1	CVS1V65910509	CVS1V65900529	CVS1V65900042
1-1/2, 2-1/2x1-1/2	CVS1V65930509	CVS1V65920529	CVS1V65920032
2, 3x2	CVS1V55080509	CVS1V55070529	CVS1V55070042
2-1/2, 4x2-1/2	CVS1V65950509	CVS1V65940529	CVS1V65940032
3	CVS1V65970509	CVS1V65960529	CVS1V65960032
4, 6x4	CVS1V65990509	CVS1V65980509	CVS1V65980022
6	CVS1V66010509	CVS1V66000529	CVS1V66000022

Key 6 Cage

"ET" and "ED" Body Size (In)	Equal Percentage			
	17-4 PH SS Hardened	316 SS		Alloy 6
		Nickel Coated	Chrome Plated	
1, 1-1/2x1, 2x1	CVS2U21533327	CVS2U74084893	CVS2U69134610	CVS2U21533910
1-1/2, 2-1/2x1-1/2	CVS2U21953327	CVS2U74094893	CVS2U69194610	CVS2U21953910
2, 3x2	CVSA2U22373327	CVS2U74104893	CVS2U269224610	CVS2U22373910
2-1/2, 4x2-1/2	CVS2U22793327	CVS2U74114893	CVS2U69254610	CVS2U22793910
3	CVS1U13213327	CVS2U74124893	CVS2U69284610	CVS2U23213910
4	CVS2U23633327	CVS2U74134893	CVS2U69314610	CVS2U23633910
6	CVS2U50593327	CVS2U80674893	CVS2U69374610	CVS2U50593910
6x4	CVS2V37233327	CVS2V37134893	CVS2V37164610	CVS2V37233910

TFE V-Ring Packing (Not Shown) (Optional materials available upon request)

Part	Stem Size (In)				
	3/8	1/2	3/4	1	1-1/4
Packing	CVS1R29000101	CVS1R29020101	CVS1R29040101	CVS1429060101	CVS1R29080101

CVS Series E Trim Parts List

Key 7, 8, 9 Disc Seat Retainer

"ET" Body Size (In)	Key 7	Key 8	Key 9
	Composition Seat		
	Disc Retainer 316 SS	Disc (TFE) -70°F to -350°F	Disc Seat 316 SS
1, 2x1	CVS1V71003507	CVS1V71710624	CVS1V71023507
1-1/2, 2-1/2x1-1/2	CVS1V71033507	CVS1V71040624	CVS1V71053507
2, 3x2	CVS1V71083507	CVS1V71070624	CVS1V71063507
2-1/2, 4x2-1/2	CVS1V71093507	CVS1V71100624	CVS1V71133507
3	CVS1V71123507	CVS1C71130624	CVS1V71143507
4	CVS1V71153507	CVS1V71160624	CVS1V71173309
6	CVS1V71183507	CVS1V71190624	CVS1V71203309
6x4	CVS1V71233507	CVS1V71160624	CVS1V71243507

Key 10 Piston Ring

"ED" Body Size (In)	TFE Carbon Filled
1, 1-1/2x1, 2x1	CVS1U2173050 9
1-1/2, 2-1/2x1-1/2	CVS1U2215050 9
2, 3x2	CVS1U2257050 9
2-1/2, 4x2-1/2	CVS1U2299050 9
3	CVS1U2341050 9
4, 6x4	CVS1U2391050 9
6	CVS1U5068050 9

Key 11 Seat Ring

"ED" Body Size (In)	Key 11 Metal Seat		
	316 SS	416 SS	ALLOY 6
1, 2x1	CVS1U22253507	CVS1U22254617	CVS1U22253910
1-1/2 x 1	CVS1U22203507	CVS1U22204617	CVS1U22203910
1-1/2, 2-1/2 x 1-1/2	CVS1U22193507	CVS1U22194617	CVS1U22193910
2, 3 x 2	CVS1U22263507	CVS1U22264617	CVS1U22263910
2-1/2, 4 x 2-1/2	CVS1U22273507	CVS1U22274617	CVS1U22273910
3	CVS1U22283507	CVS1U22284617	CVS1U22283910
4	CVS1U22293507	CVS1U22294617	CVS1U22293910
6	CVS1U50803507	CVS1U50804617	CVS1U50803910
6 x 4	CVS2V37193507	CVS2V37194617	CVS2V37204605

Key 12 Seat Ring Adaptor and Key 13 Cage Adaptor

"ED" Body Size (In)	Key 12 Seat Ring Adaptor			"ED" Body Size (In)	Key 13 Cage Adaptor		
	Iron & Steel	316 SS	C-5 Chrome Moly		Iron & Steel	316 SS	C-5 Chrome Moly
1-1/2 x 1	Not Req'd	Not Req'd	Not Req'd	1-1/2 x 1	CVS1U22182440	CVS1U22183507	CVS1U22183507
2 X 1	CVS1U22622449	CVS1U22623507	CVS1U22623507	2 x 1	CVS1U12072449	CVS1U12073507	CVS1U12073507
2-1/2 x 1	CVS1U23042449	CVS1U23043507	CVS1U23043507	2-1/2 x 1	CVS1U23022449	CVS1U23023507	CVS1U23023507
3 x 2	CVS1U23462449	CVS1U23463507	CVS1U23463507	3 x 2	CVS1U12462201	CVS1U12463309	CVS1U12462902
4 x 2-1/2	CVS1U23962449	CVS1U23963507	CVS1U23963507	4 x 2-1/2	CVS1U12512201	CVS1U12513309	CVS1U12512902

Gaskets (Not Shown) Temperature to 800°F

"ET" Body Size (In)	Gaskets				
	Gasket Set	Bonnet	Cage	Spiral Wound	Seat Ring
1	CVS1R2860X001	CVS1R2859	CVS142861	CVS1R2860	CVS1R2862
1-1/2	CVS1R3099X001	CVS1R3101	CVS1R3100	CVS1R3099	CVS1R3098
2	CVS1R3297X001	CVS1R3299	CVS1R3298	CVS1R3297	CVS1R3296
2-1/2	CVS1R3845X001	CVS1R3847	CVS1R3846	CVS1R3845	CVS1R3844
3	CVS1R3482X003	CVS1R3484	CVS1R3483	CVS1R3482	CVS1R3481
4	CVS1R3722X001	CVS1R3724	CVS1R3723	CVS1R3722	CVS1J5047
6	CVS1U5085X001	CVS1U5081	CVS1U5083	CVS1U5085	CVS1U5086
6 x 4	CVS1U5085X001	CVS1U5081	CVS1U5081	CVS1U5081	CVS1U5081

Optional materials available. Consult CVS Controls.

CVS Series E Dimensional Data

Steel Bodies through 600lb Rating

Size		Dimension A ¹											
		150 RF		150 RTJ		300 RF		300 RTJ		600 RF		600 RTJ	
In	Mm	In	Mm	In	Mm	In	Mm	In	Mm	In	Mm	In	Mm
1	25.4	7.25	184.2	7.75	196.9	7.75	196.9	8.25	209.6	8.25	209.6	8.25	209.6
1-1/2	38.1	8.75	222.3	9.25	235.0	9.25	235.0	9.75	247.7	9.88	251.0	9.88	251.0
2	50.8	10.00	254.0	10.50	266.7	10.50	266.7	11.13	282.7	11.25	285.8	11.38	289.1
2-1/2	63.5	10.88	276.4	11.38	289.1	11.50	292.1	12.13	308.1	12.25	311.2	12.38	314.5
3	76.2	11.75	298.5	12.25	311.2	12.5	317.5	13.13	333.5	13.25	336.55	13.38	339.9
4	101.6	13.88	352.6	14.38	365.3	14.51	368.3	15.13	384.3	15.50	393.7	15.63	397.0
6	152.4	17.75	450.9	18.25	463.6	18.63	473.2	19.25	489.0	20.00	508.0	20.13	511.3

Size		Dimension C											
		150 RF		150 RTJ		300 RF		300 RTJ		600 RF		600 RTJ	
In	Mm	In	Mm	In	Mm	In	Mm	In	Mm	In	Mm	In	Mm
1	25.4	2.13	54.1	2.13	54.1	2.13	54.1	2.13	54.1	2.13	54.1	2.13	54.1
1-1/2	38.1	2.44	6.19	2.44	6.19	2.44	6.19	2.44	6.19	2.44	6.19	2.44	6.19
2	50.8	2.88	73.2	2.88	73.2	2.88	73.2	2.88	73.2	2.88	73.2	2.88	73.2
2-1/2	63.5	3.44	87.4	3.44	87.4	3.44	87.4	3.44	87.4	3.44	87.4	3.44	87.4
3	76.2	3.56	90.4	3.56	90.4	3.56	90.4	3.56	90.4	3.56	90.4	3.56	90.4
4	101.6	4.69	119.1	4.69	119.1	4.81	119.1	4.81	119.1	4.94	125.5	4.94	125.5
6	152.4	5.19	131.8	5.31	134.9	5.31	134.9	5.50	139.7	5.50	139.7	5.50	139.7

Size		Dimension D											
		Standard Bonnet						Extension Bonnet					
		Stem Size						Stem Size					
In	mm	3/8	9.5	1/2	12.7	3.4	19.1	3/8	9.5	1/2	12.7	3.4	19.1
		In	Mm	In	Mm	In	Mm	In	Mm	In	Mm	In	Mm
1	25.4	5	127.0	5.88	150	---	---	8.38	212.8	9.88	251.0	---	---
1-1/2	38.1	4.88	123.8	5.75	146.1	---	---	8.25	209.6	9.75	247.7	---	---
2	50.8	---	---	6.50	165.1	6.38	162.1	---	---	10.50	266.7	10.50	266.7
2-1/2	63.5	---	---	7.38	187.5	7.25	184.2	---	---	11.38	289.1	11.56	293.6
3	76.2	---	---	7.50	190.5	7.38	187.5	---	---	11.50	292.1	11.69	296.9
4	101.6	---	---	8.69	221.0	8.56	217.4	---	---	12.69	322.3	12.88	327.2
6	152.4	---	---	---	---	9.88	251.0	---	---	---	---	14.06	357.1

1. Dimension B = A divided by 2
 RF=Raised Face RTJ=Ring Type Joint
 Flange Specification ASME/ANSIB16.5 - 1996

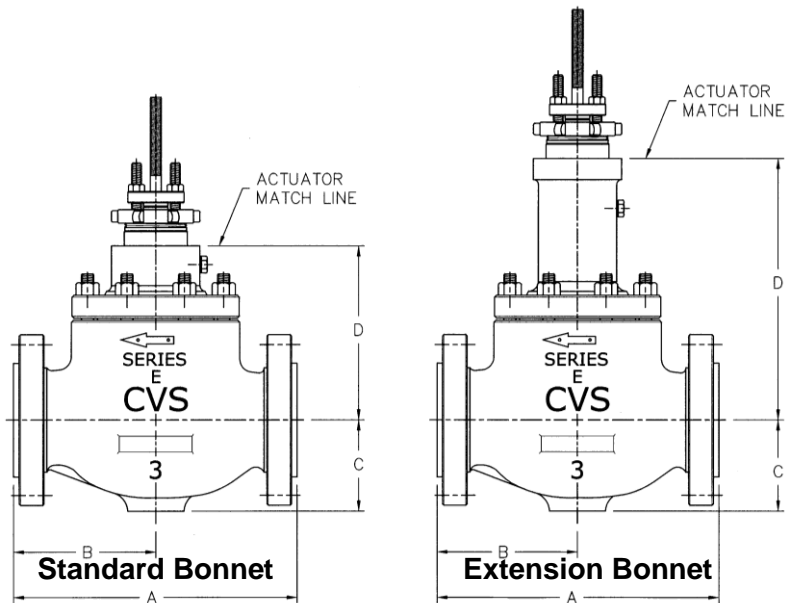

Notes

Notes

CVS Controls Ltd. strives for the highest levels of quality and accuracy. The information included in this publication is presented for informational purposes only. CVS Controls Ltd. reserves the right to modify or change, and improve design, process, and specifications without written notice. Under no circumstance is the information contained to be interpreted to be a guarantee/warranty with regard to our products or services, applicability or use. Selection, use and maintenance are the sole responsibility of the end user and purchaser. CVS Controls assumes no liability for the selection use and maintenance of any product.

CVS

CONTROLS

Head Office

3900 – 101 Street
Edmonton, Alberta, Canada T6E 0A5
Office: (780) 437-3055
Fax: (780) 436-5461

Calgary Sales Office

3516 114 Avenue SE
Calgary, Alberta, Canada T2Z 3V6
Office: (403) 250-1416
Fax: (403) 291-9487

Website: www.cvs-controls.com E-Mail: info@cvs-controls.com