

CVS Series 252

Filter

The CVS Series 252 Filter may be utilized to filter air or clean gas prior to entering pressure pilots, pilot operated regulators, or pneumatic instruments that require clean mediums for continued and efficient operations. When using a CVS Series 252 Filter in the installation, it will prevent contaminants and moisture from entering the devices and equipment it is protecting. This will reduce down time for maintenance and help increase overall efficiency.

The Filter is standard 316 stainless steel, and available in a regular or extended body configuration. The extended body configuration allows for an increased storage capacity to remove and filter debris from the air or gas process. A stainless steel drainplug is standard on the CVS 252.

NACE Compatible. Providing a filtration capability of 20 microns. Maximum working pressure of 2750 psig.



CVS Series 252 Filter

SPECIFICATIONS

Inlet and Outlet Connections:

1/4" NPT

Maximum Working Pressure:

Standard Configuration – Stainless Steel: 2750 psig (190 bar)

Temperature Capabilities:

-40°C to 82°C (-40°F to 180°F)

Filter Rating:

20 Microns

Maximum Differential:

100 psig (6.9 bar)

Approximate Shipping Weight:

Standard body, Stainless Steel – 2.3 lbs (1kg)

Extended body, Stainless Steel – 3 lbs (1.4kg)

NACE MRO175

Materials:

Body – 316 Stainless Steel

Filter Cartridge – Polyethylene

Oring – NBR Nitrile

Drain Valve – Stainless Steel

INSTALLATION

Always follow proper safety and lockout procedures when installing. Use proper piping practices to prevent incorrect installations, leakage or personal injury. Never exceed the pressure and temperature limits listing in this manual or on the tag of the filter itself. Ensure all pressure has been relived completely prior to maintenance or servicing.

Inspect the filter prior to installation to ensure it is clear and free from any debris or obstructions. Follow best piping practices when installing. Inlet and outlet connections are clearly marked on the filter housings. Inlet and outlet connections are 1/4" NPT. Use a quality compound on the external pipe threads and check for leaks prior to putting into full service.

MAINTENANCE:

The severity of service may require increased inspection and or maintenance if required. Inspect for leaks and or damage and repair or replace as required. If removing body (2) in order to inspect or replace the filter (4), always inspect the oring (7) and replace if required, lubricate the oring prior to reinstalling. Inspect drain valve to make sure free of dirt or debris which may restrict flow.



CVS Series 252 Filter – Standard Body – Assembly and Dimensions

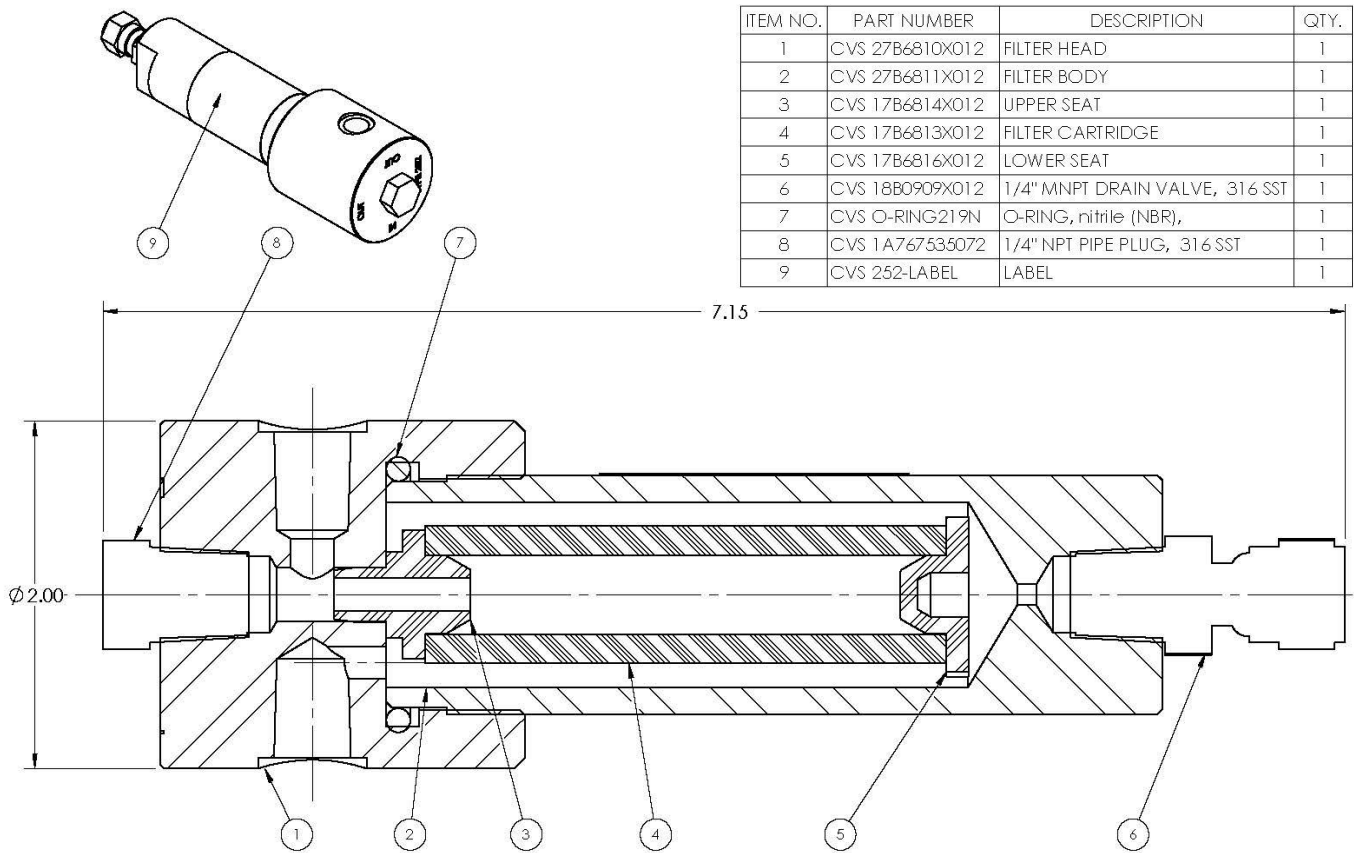

ITEM NO.	PART NUMBER	DESCRIPTION	QTY.
1	CVS 27B6810X012	FILTER HEAD	1
2	CVS 27B6811X012	FILTER BODY	1
3	CVS 17B6814X012	UPPER SEAT	1
4	CVS 17B6813X012	FILTER CARTRIDGE	1
5	CVS 17B6816X012	LOWER SEAT	1
6	CVS 18B0909X012	1/4" MNPT DRAIN VALVE, 316 SST	1
7	CVS O-RING219N	O-RING, nitrile (NBR),	1
8	CVS 1A767535072	1/4" NPT PIPE PLUG, 316 SST	1
9	CVS 252-LABEL	LABEL	1

CVS Series 252 Filter – Extended Body – Assembly and Dimensions

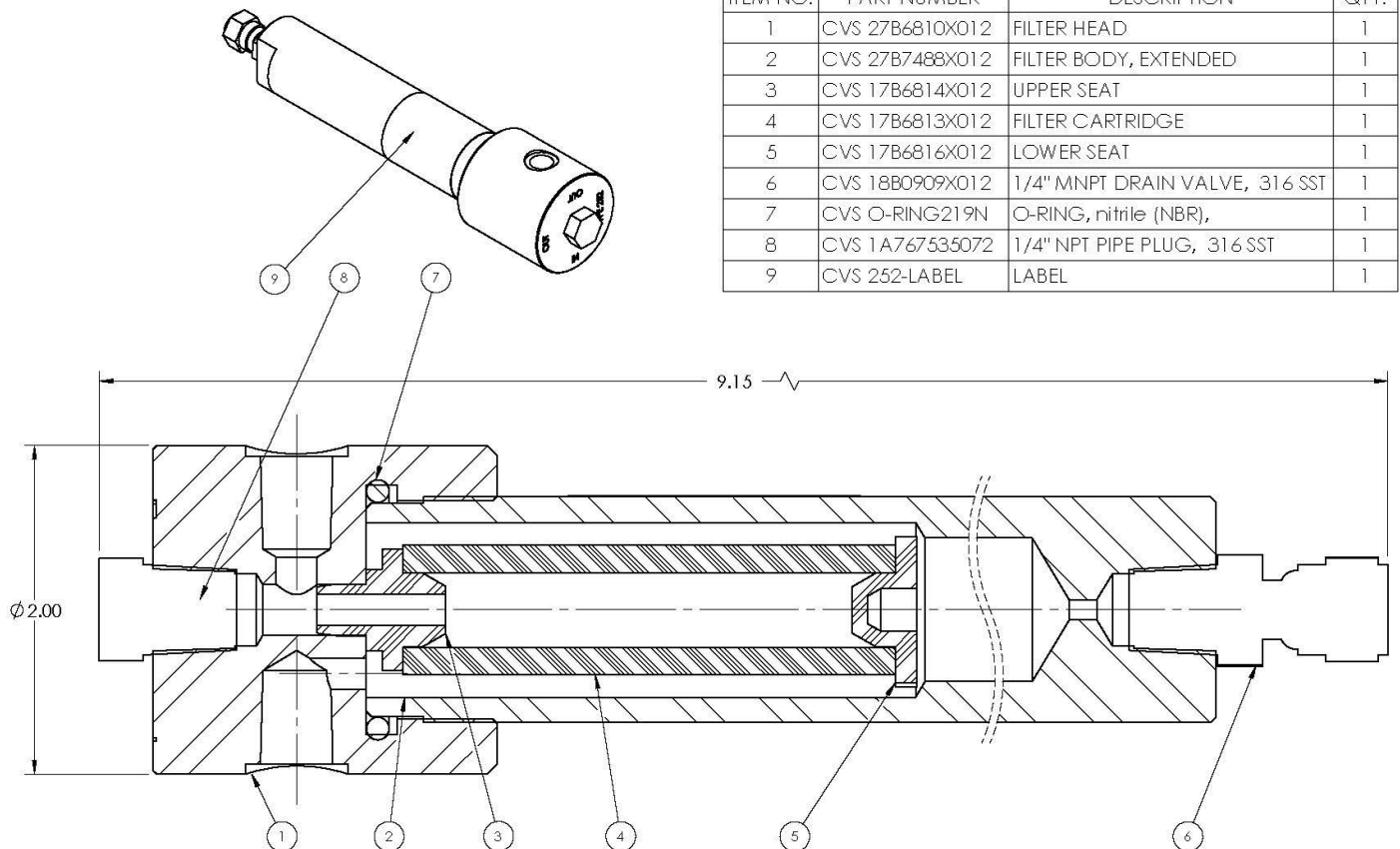

ITEM NO.	PART NUMBER	DESCRIPTION	QTY.
1	CVS 27B6810X012	FILTER HEAD	1
2	CVS 27B7488X012	FILTER BODY, EXTENDED	1
3	CVS 17B6814X012	UPPER SEAT	1
4	CVS 17B6813X012	FILTER CARTRIDGE	1
5	CVS 17B6816X012	LOWER SEAT	1
6	CVS 18B0909X012	1/4" MNPT DRAIN VALVE, 316 SST	1
7	CVS O-RING219N	O-RING, nitrile (NBR),	1
8	CVS 1A767535072	1/4" NPT PIPE PLUG, 316 SST	1
9	CVS 252-LABEL	LABEL	1