



Technology Solutions

# TEK-CLAMP 1200A

## Ultrasonic Clamp-On Flowmeter



FLOW



## Introduction

Tek-Clamp 1200A Ultrasonic Clamp-On Flowmeter is designed to measure the velocity of liquid in a full or closed pipe. It is a measurement system which is both easy to install and use. The Tek-Clamp 1200A operates according to the difference in the Transit Time of Flight measured, and determines the flow velocity by measuring the travel time of a pulse from one transducer to the next. Flow in the same direction takes less time to travel to the second transducer than the flow in the opposite direction. Electro-acoustic transducers receive and emit brief ultrasonic pulses through the liquid of the pipe. Transducers are vertically placed at both sides of the measured pipe. Sensors are placed on the pipe and fastened by means of a clamp. The Tek-Clamp 1200A can be used for metallic, plastic, and rubber tubes.

## Measuring Principle

When the ultrasonic wave is transmitted through the flowing liquid, there will be a difference between the upstream and downstream transit time (travel time or time of flight), which is proportional to flow velocity. When fluid is flowing, counter flow transit time is more than direct flow transit time.

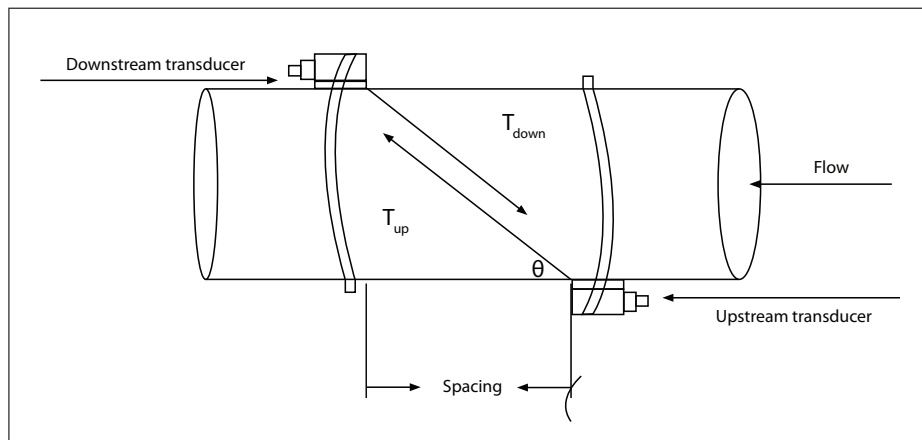

The formula for calculating velocity is:

$$V = \frac{MD}{\sin 2\theta} \times \frac{\Delta T}{T_{up} \times T_{down}}$$

$\theta$  is the include angle to the flow direction

$M$  is the travel times of the ultrasonic beam

$D$  is the pipe diameter

$T_{up}$  is the time for the beam from upstream transducer to the downstream one

$T_{down}$  is the time for the beam from downstream transducer to the upstream one

$$\Delta T = T_{up} - T_{down}$$

## Tek-Clamp 1200A Ultrasonic Clamp-On Flowmeter

- **Tek-Clamp 1200A-100F1 (Wall Mount Ultrasonic Flowmeter)**

Tek-Clamp 1200A-100F1 accurately captures flow measurements using three approaches: Clamp-on, flow-cell, and insertion. The positive, negative, net totalizer flow rate, and heat quantity from the last 10 years is stored in the memory.



- **Tek-Clamp 1200A-100M (Low Cost DIN Mount Flowmeter)**

The Tek-Clamp 1200A-100M modular ultrasonic flowmeter can work without a LCD and Keypad module. So the module can be used alone as a flowmeter. Users can even integrate a number of the modules into a multi-channel flowmeter that can measure different pipes. The meter is designed in such a way that it provides high performance at a cheaper cost.



- **Tek-Clamp 1200A-100H (Hand Held Ultrasonic Flowmeter)**

Tek-Clamp 1200A-100H is a completely non-invasive ultrasonic flowmeter that uses ultrasonic signal to measure the flow rates with the transit time method. The unit has a built-in data logger for over 2000 lines of data and is optional as an external data logger. Tek-Clamp 1200A-100H has a pair of transducers capable of measuring flow rates in pipes from ½" (0.04 ft) to 28" (2.33 ft) at temperatures of between 32 °F (0 °C) to 320 °F (160 °C).



## Features

	Tek-Clamp 1200A-100F1	Tek-Clamp 1200A-100M	Tek-Clamp 1200A-100H
<b>Accuracy</b>	Better than 1% accuracy	Better than 1% accuracy	Better than 1% accuracy
<b>LCD Display</b>	2 × 20 LCD Display	2 × 20 English letters LCD display	4 × 16 LCD Display
<b>Size</b>	Pipe diameters from ½" to 28"	Pipe diameters from ½" to 28"	Pipe diameters from ½" to 28"
<b>Protection Category</b>	IP65	IP57	Clamp-on IP65 sensors
<b>Output Signal</b>	Modbus RS485, 4-20 mA, and Pulse	Modbus RS485, 4-20 mA, and Pulse	None
<b>Power Supply</b>	85-264 VAC or 24 VDC power supply	8-36 VDC	90-230 VAC power supply, Ni-MH battery operation for over 12 hours
<b>Keypad</b>	4 × 4 key tactile-feedback membrane keypad	4 key tactile-feedback membrane keypad	-

## Application

- Water and waste water treatment plant
- Power plant, such as nuclear power plants and hydraulic power plants
- Mining and metallurgy plants
- Petroleum process monitoring and control
- Chemical process monitoring and control
- Pulp and paper process monitoring and control
- Food and beverage processing
- Marine maintenance and operation
- Energy supply and production system
- Flow measurement networking

## Dimensional Drawings

### Dimension for Tek-Sonic 1200A-100F1

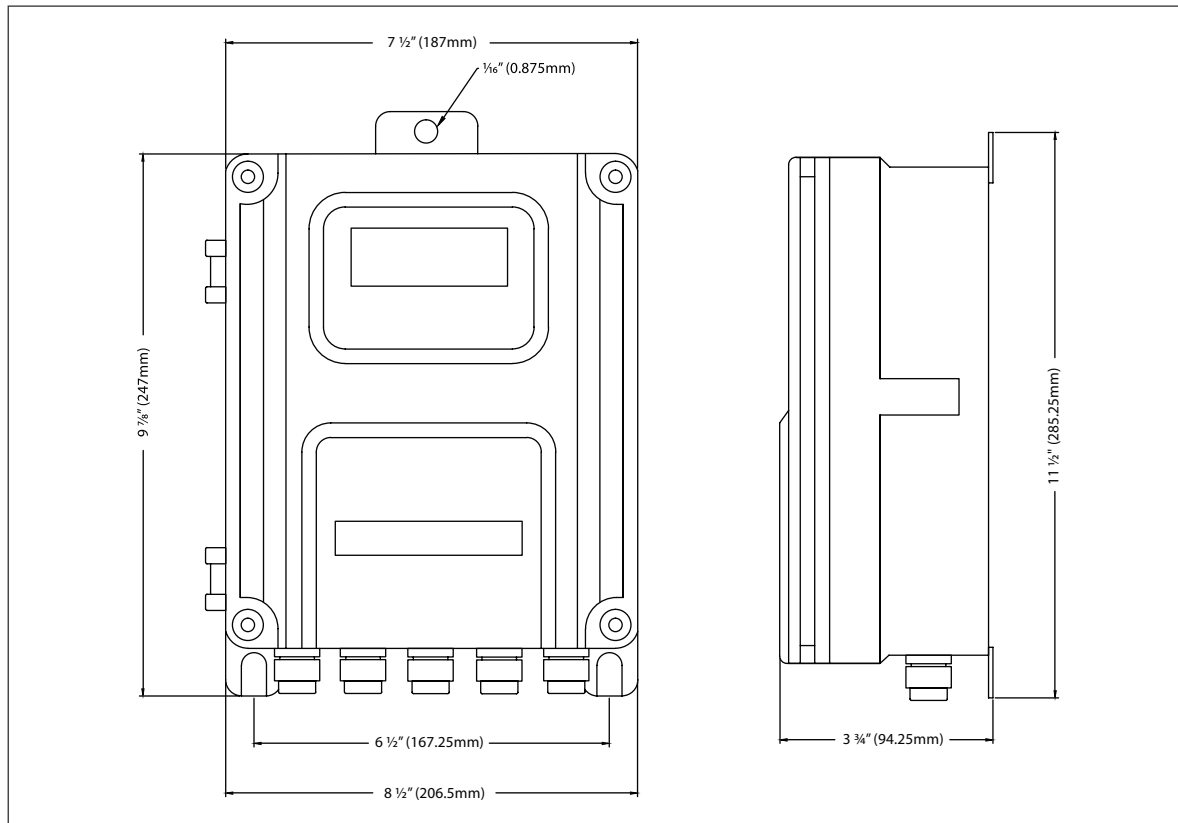

## Sensor Drawings

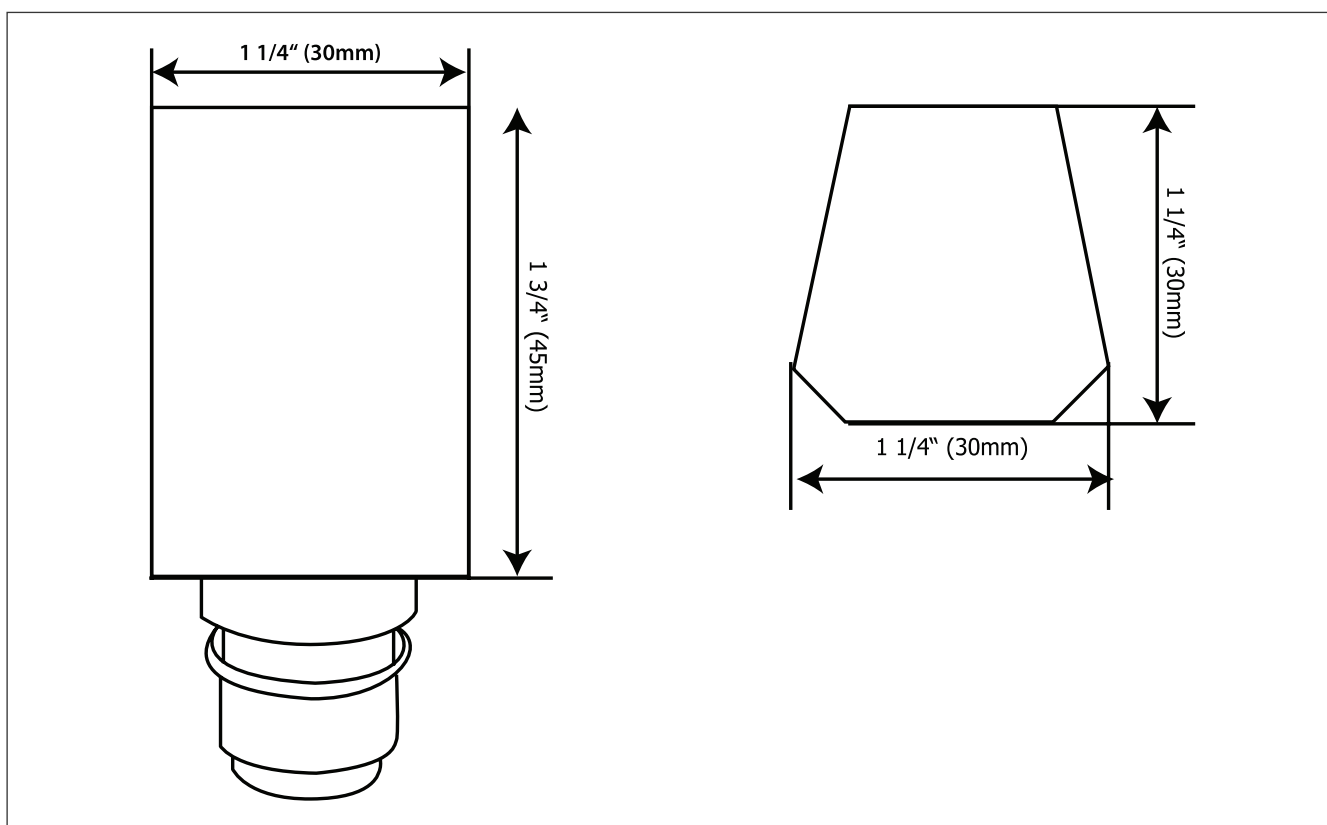

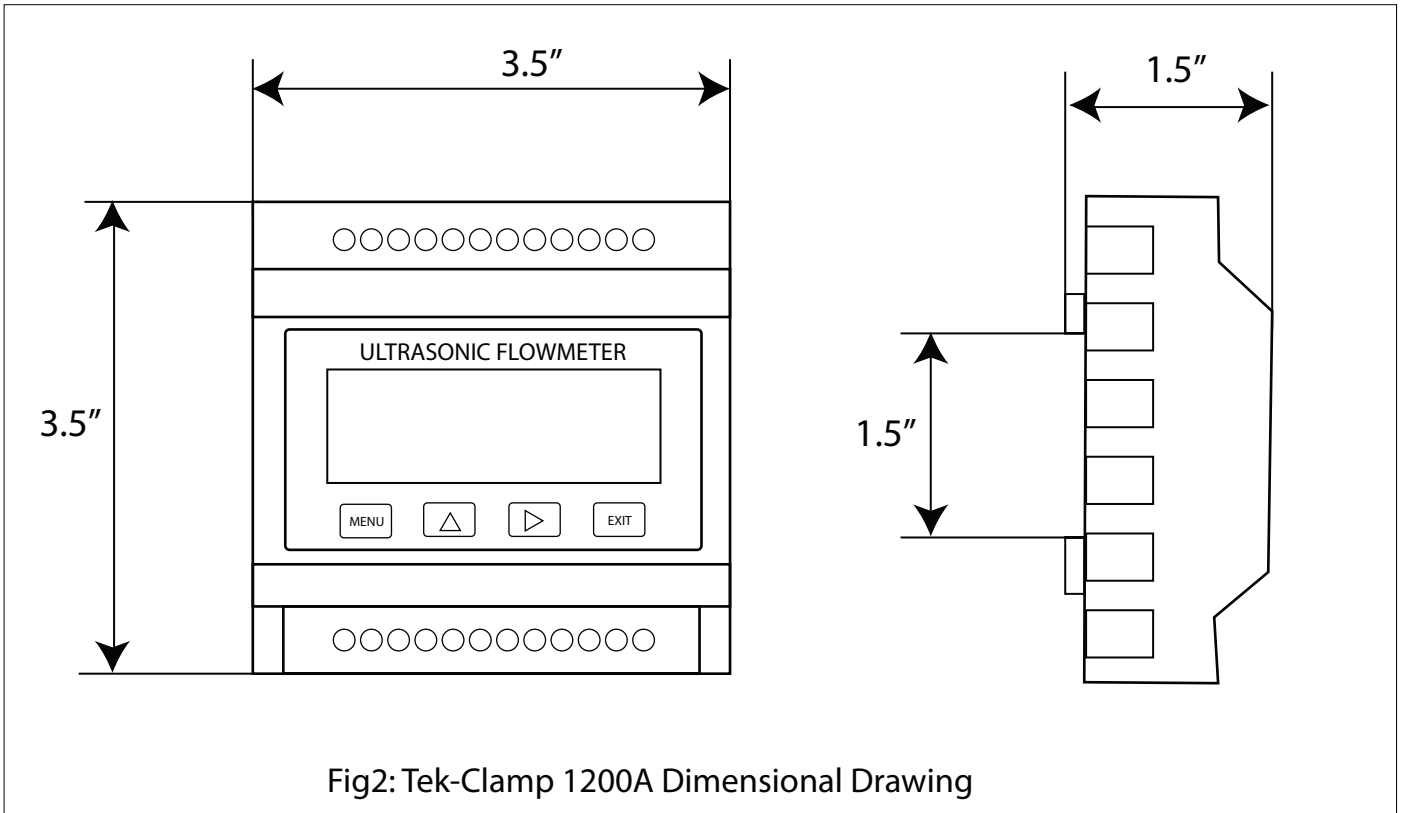
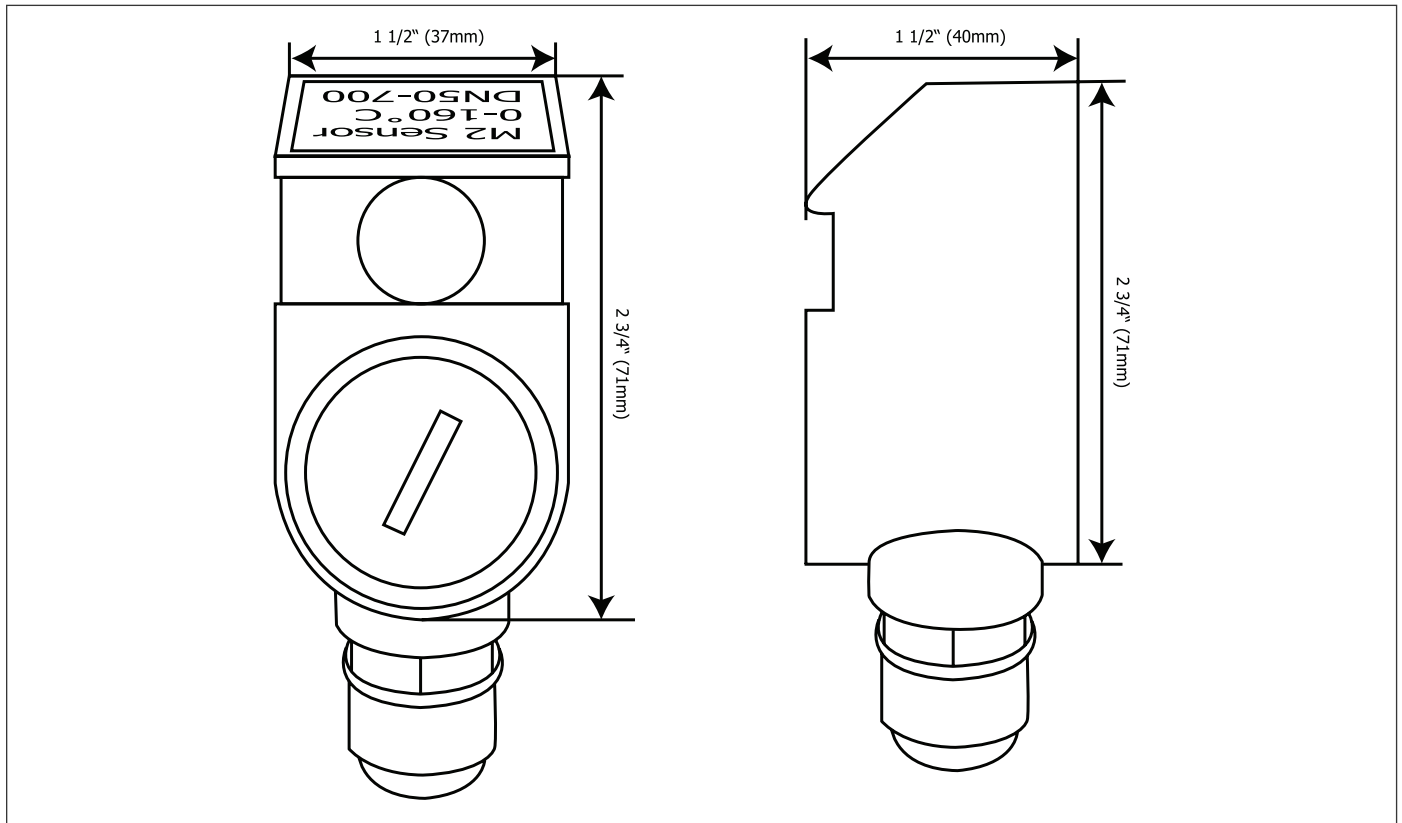

Fig2: Tek-Clamp 1200A Dimensional Drawing

## Specification

Parameters		Specification	
Main Unit	Accuracy	±1% of Reading	
	Velocity	±0.03 to ±100 ft/s (±0.01 to ±30m/s)	
	Repeatability	0.2%	
	Measurement Period	0.5 Seconds	
	Measurement Principle	Transit-time measurement principle	
	Display	LCD with backlight. 2 x 20 letters	
	Output	100F1	Modbus RS485 4-20 mA, Pulse
		100M	Modbus RS485 4-20 mA, Pulse
		100H	None
	Input	Two three wire system PT100 platinum resistor input loop. For BTV process monitoring	
	Other Functions	Automatically stores the memory of the positive, negative, net totalizer flow rate and heat quantity of the last 512 days, 128 months, 10years	
	Power	100F1	85 to 264 VAC or 8 to 36 VDC
		100M	8 to 36 VDC
		100H	Rechargeable nickel metal hydride battery
	Power Consumption	Less than 1.5W	
Environment Temperature	-22 °F to 176 °F (-30 °C to 80 °C)		
Environment Humidity	85% RH		
Protection Class		IP65 (Tek-Clamp 1200A-100F1)	
		IP57 (Tek-Clamp 1200A-100M and 1200A-100H)	
Transducers	Clamp-On	S2-type: for pipe size ½"- 4" (15mm to 100mm) M2-type: for pipe size 2"- 28" (50mm to 700mm) HS-type: for pipe size ½"- 4" (15mm to 100mm) HM-type: for pipe size 2"- 28" (50mm to 700mm)	
	Protection Class	IP68, can work in water with depths less than 10' (3 m)	
Liquids	Types	Virtually all commonly used clean liquids. Liquids with small quantity of tiny particles may also be applicable. Particle size should be less than 75 um, particle concentration less than 20,000 ppm. Liquids should contain no or very minor air bubbles.	
	Process Temperature	-40 °F to 320 °F (-40 °C to 160 °C)	
Pipe	Pipe Material	All metals ,most plastics, fiber glass, etc.	
	Pipe Size	½" – 28" (15mm to 700mm)	
	Pipe Straight Run	More than 10 D for upstream, more than 5 D for downstream, 30 D if a pump is near upstream, where D is pipe diameter.	

## Transducer Selection

- Clamp-On Transducer

A pair of clamp-on transducers measure the flow from outside of a pipe. There is no pressure drop, no leaks, and no contamination. The installation is very simple and no special skills or tools are required.

Technical Parameters	HS-Type	HM-Type	S2-Type	M2-Type
Pipe Size (inch)	(½" – 4")	(2"– 28")	(½" – 4")	(2" – 28")
Pipe Size (ft)	(DN 0.04-DN 0.33)	(DN 0.16-DN 2.33)	(DN 0.04-DN 0.33)	(DN 0.16-DN 2.33)
Material	Aluminum alloy		Plastic Alloy	
Frequency	1MHz			
Installation Method	V (N/V)	V/Z	V(N/W)	V/Z
Mounting	Magnetic and pipe clamp			
Temperature	32 °F to 320 °F (0 °C to 160 °C)			
Protection Class	IP65			
Cable	Shielded Transducer cable, Standard length 16 ft × 2, Can be extended up to 49 ft			

## Installation

To ensure measurement accuracy and stability, the installation point of transducers should be on the straight pipe full of well distributed fluid (when installing, the pipe must be full of liquid), and should follow the given points:

- Pipe must be full of liquid that is uniform and easy for the ultrasonic pulse to travel through (vertical pipe or horizontal pipe).
- Avoid installing the transducer at the highest point of pipe system or on the vertical pipe with free exit (down flow).

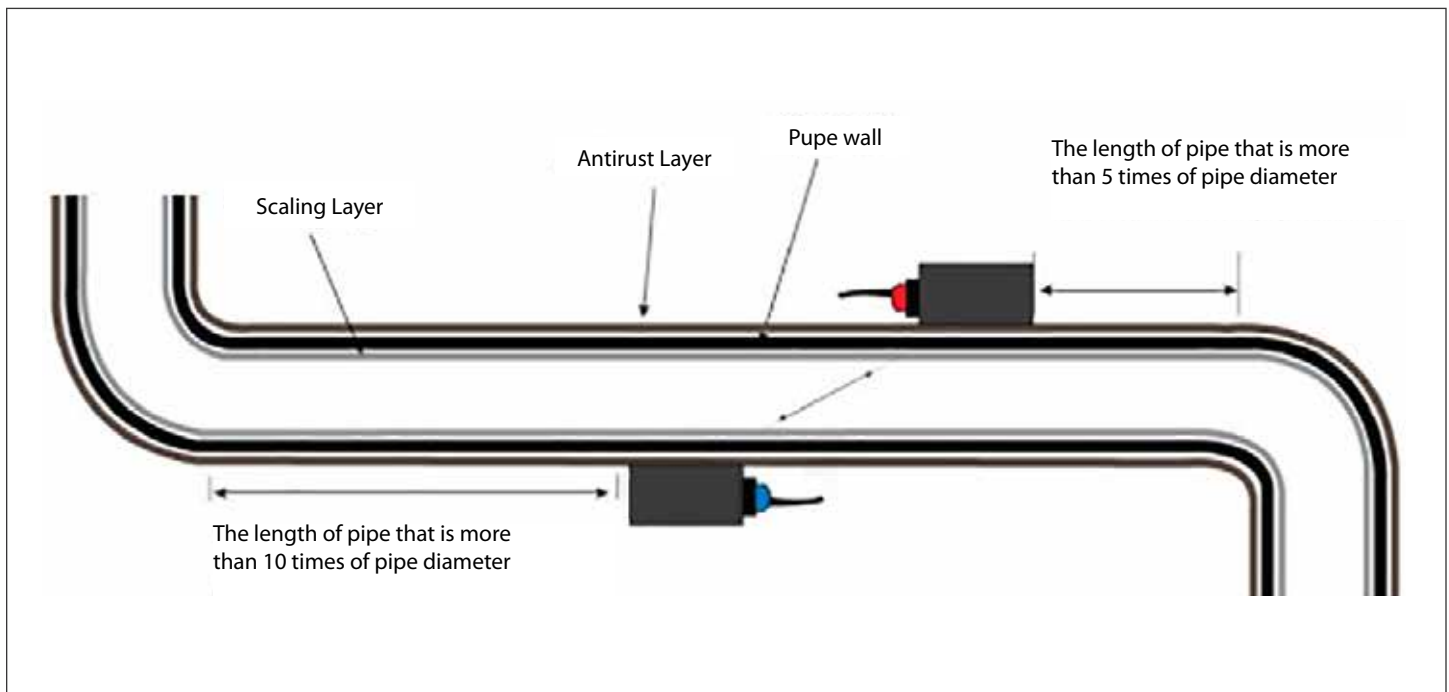



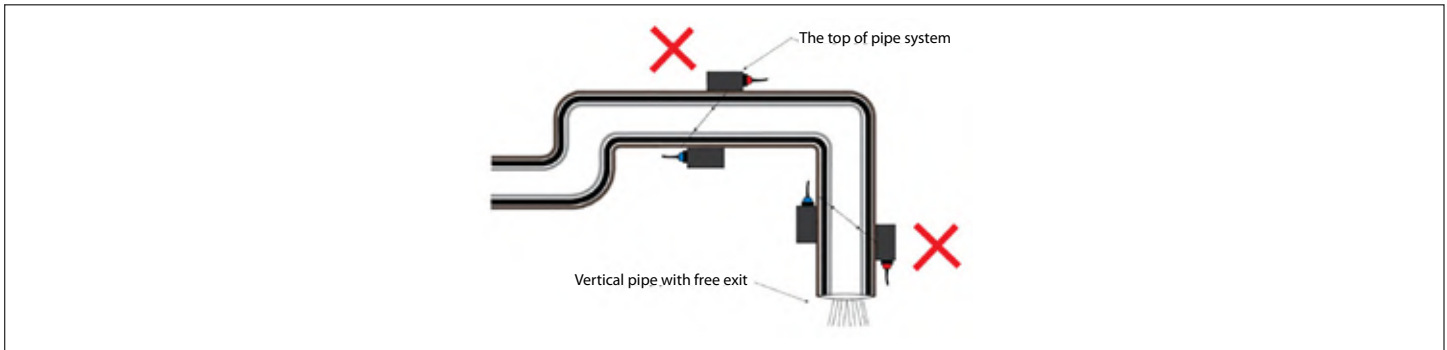

- For the open pipe or half full pipe, the transducers should be installed at the bottom of U pipe.

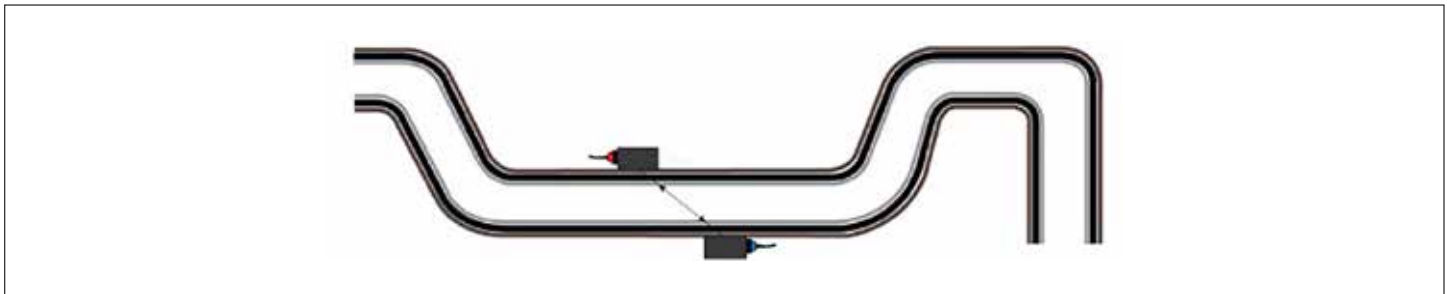

- The temperature and pressure on the installation point should be within the work ability of the transducers.
- Pay attention to the pipe's inner wall and check for pollution build-up. Select a pipe without any or very little build-up of sediment because it may interfere with the signal.
- In case of horizontal piping, mount the detector within  $\pm 45^\circ$  from the horizontal plane. Otherwise, the measurement could be impossible if bubbles stay in the upper part of piping or if deposits are accumulated in the lower part of piping. In case of vertical piping, the detector may be mounted at any position on its periphery provided that the flow is upward.

## Model Chart

Model Number	Description
Note: Controller, Sensors, and Options are all ordered individually	
<b>Controllers</b>	
1200A-100F1	Wall Mount Ultrasonic Flow Meter
1200A-100M	Low Cost DIN Mount Flow Meter
1200A-100EXP	Explosion Proof Ultrasonic Flow Meter
1200A-100H	Hand Held Ultrasonic Flow Meter (with carrying case)
<b>Transducers</b>	
1200A-S2	½" to 4" Pipe (Wall and DIN Controller)
1200A-M2	2" to 28" Pipe (Wall and DIN Controller)
1200A-L2	12" to 200" Pipe (Wall or DIN Controller)
1200A-IM	Insertion Sensor 3" to 7" Pipe (Wall or DIN Controller)
1200A-IL	Insertion Sensor 3" to 12" Pipe (Wall or DIN Controller)
1200A-S2H	½" to 4" Pipe (Hand Held)
1200A-M2H	2" to 28" Pipe (Hand Held)
1200A-HSH	½" to 4" Pipe, Bracket Mounted Sensors (Hand Held)
1200A-HMH	2" to 28" Pipe, Bracket Mounted Sensors (Hand Held)
<b>Accessories</b>	
1200A-TM8812	Ultrasonic Thickness Gauge
1200A-SEYV75-2-5	Junction box and two 16' Extension Cables
1200A-BIT	Drill Bit for Insertion Sensors
1200A-Gel	Coupling Gel