



Technology Solutions

TEK-DP 1620A

Cone Meter



FLOW



Introduction

Tek-DP 1620A Cone Meters are manufactured and designed for measuring multiple fluid types from gases to liquids and vapors, the meter uses differential pressure to provide accurate, repeatable and low cost of ownership measurement solutions.

All Tek-DP Cone Meters read flow rates by using by a differential pressure or multi-variable transmitter in conjunction with a flow computer in certain world regions chart recorders are still used which will operate with a cone meter.

The method used to connect the transmitter to the meter varies, depending on the type of product measured and available space for mounting the meter in the supporting pipework. This operator manual provides installation instructions and some piping diagrams for using the Cone Meter in liquid, gas, and steam applications.

Main Meter Components

The Cone Meter comprises three main components, as shown in figure 1 and figure 2.

- Meter body or tube (closed conduit) with or without flanges.
- Differential Pressure Cone assembly, either fabricated or machined from a mono-block stainless/other steel piece (not carbon) positioned in the center of the meter tube.
- A pair of pressure tapping's - wall tap upstream and a sensing tap downstream with a pressure sensing conduit for reading differential pressures at the center of the cone and meter body.

***Note:** a downstream wall-tap may be used under certain process measurement conditions.

All Tek-DP Meters can be manufactured from various materials (Carbon-A105/106/LF350 steels etc., stainless, or duplex stainless steel) to meet specific process requirements for metering: natural gas steam, air, nitrogen, ethanol, digester gas and a host of hydrocarbon and non-Hydrocarbon liquids from crude oil to wastewater and cryogenic products.

The TEK-DP 1620A Cone Meter is manufactured to meet the ISO 5167 Part 5 DP Cone Meter Standard when applied for custody transfer applications the same dimensions and geometry is used for other cone meter types with certain exceptions such as wall taps for vertical flow orientations and extra taps for smart metering operations.

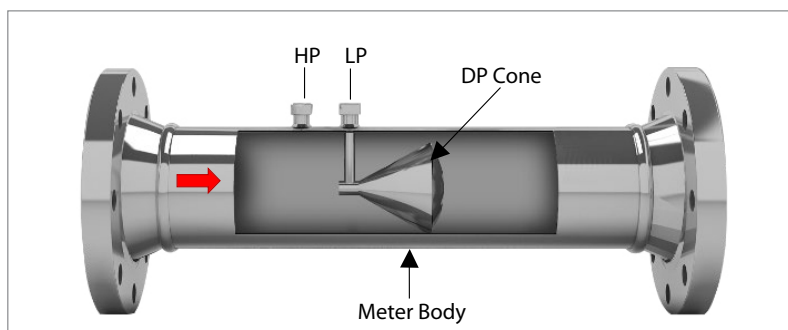

Fig 1: Basic components of Tek-DP 1620A Cone Meter

The Tek-DP 1620A Cone Meter has no moving parts and is designed to ISO 5167 Part 5 Geometries. There are no stagnation areas at the DP meter element where trash or fluid particles can lodge within the measurement section during normal flowing conditions.

The meter is virtually maintenance-free due to the self-cleaning action at the cone beta edge which resides downstream of the flow .

Measuring Principle

The Tek-DP 1620A Cone Meter generates a differential pressure across a centrally fixed cone shape that can be used to calculate fluid flow rates using ISO 5167 Part 5 published equations.

A DP or MVT transmitter measures the differential pressure and outputs an integrated electronic signal, typically via standard Modbus or a 4-20mA output to a flow measurement computer with cone meter equations installed, or other process control tertiary device for readout and review. For compressible fluids (gases), line pressure and temperature measurements are required for accurate flow rate calculations such as custody transfer applications as well as compensation for any adiabatic changes in the meter expansion factor also detailed in ISO 5167 Part 5. During normal operation process fluids flow around the differential producer cone, and pressure drop occurs according to Bernoulli principles of conservation of energy. The static line pressure (P1) is measured via a wall tap strategically located upstream of the cone (Figure 2). Pressure is also measured via a sensing tap that is connected to the cone center using a conduit and measures pressure at a central point immediately downstream of the cone (P2). The fluid flow-rate is calculated using the differential pressure(DP).

The principle of the conservation of mass and energy applies to cone meters thus, a flow rate Q is proportional to the Square Root of the DP. The pipe area is based on the internal pipe diameter and the area reduction being the annulus area at the cone beta edge. This relationship is called the beta ratio (β) for DP Cone Meters this is calculated as being:

$$\beta = \sqrt{1 - \frac{d^2}{D^2}}$$

Where, D is pipe Diameter.
d is Cone Diameter.

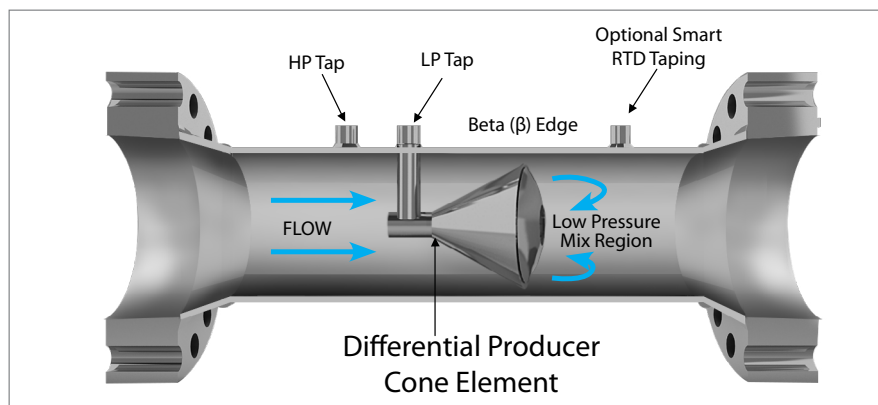

Fig 2: TEK-DP 1620A DP Cone Meter (Cutaway View – Flow Streams)

The meter differential producer cone element reshapes the fluid velocity profile directly upstream and across the expanding element conditioning flows naturally and eliminating the need for traditional flow conditioners or long straight lengths. Tek-DP 1620A Cone Meter can therefore be installed in shorter meter runs than those required by a conventional differential pressure meter and high degrees of performance are ensured even under extremely disturbed flow conditions.

Operations

All Tek-DPro DP Cone Meters are fabricated and assembled using ASME approved welding techniques. Welder qualifications and material certification available to 3.1b and 3.1c quality requirements with full material traceability either in standard steels or exotics.

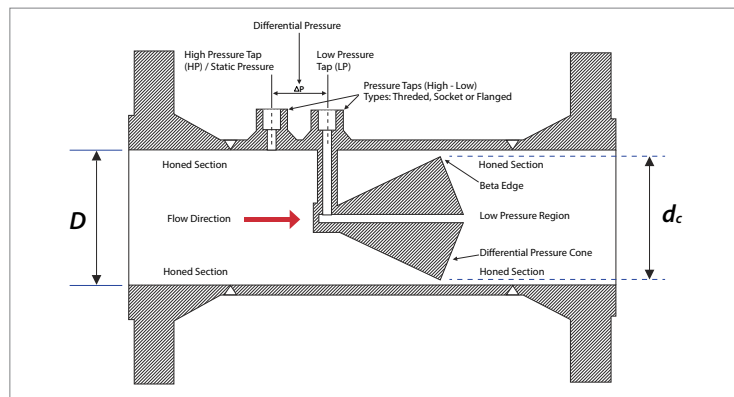

Fig 3: Tek-DP 1620A DP Cone Meter

TEK-DPro Cone Meters are manufactured with attention to their geometry and metrology based on ISO Standards. All up and downstream weld-neck seam welds are honed to provide smooth entry & exit into and out of the cone meter measurement section.

This honing procedure minimizes fluid jetting effects entering the meter throat/annulus that may occur at certain higher fluid Re_D numbers.

***Note:** Jetting effects occur where weld beads protrude into the flow stream and may cause an over-run of the flow conditioning effect provided by the meter DP element. This effect is particularly evident on larger beta ratios, it is good practice to always implement this operation in the manufacturing process of a cone meter.

System Components

A transmitter, valve manifold, shut-off valves, and impulse tubing are typically required for the operation of a Tek-DP 1620A Cone Meter. If the meter is used to measure steam, a condensate pot may also be required.

Differential Pressure Transmitters

A differential pressure transmitter records the differential pressure signal generated by the cone meter and provides an analog or serial output to a flow computer or data control system. The transmitter(s) selected for an installation must be appropriate for operating conditions of the process in terms of both accuracy and safety. DP devices must be zeroed following installation. The procedure varies somewhat for liquid, gas, and steam applications.

Shut-Off Valves

Choose a block valve that is rated for the operating pressure of the pipe in which it will be installed. Where dangerous or corrosive fluids or gases like oxygen are likely, the block valve and packing must provide ample protection.

***Note:** The valves must not affect the transmission of the differential pressure signal.

Install block valves next to the Tek-DP 1620A Cone Meter pressure taps. Never use a globe valve for differential pressure transmission lines. (See: Figure 4)

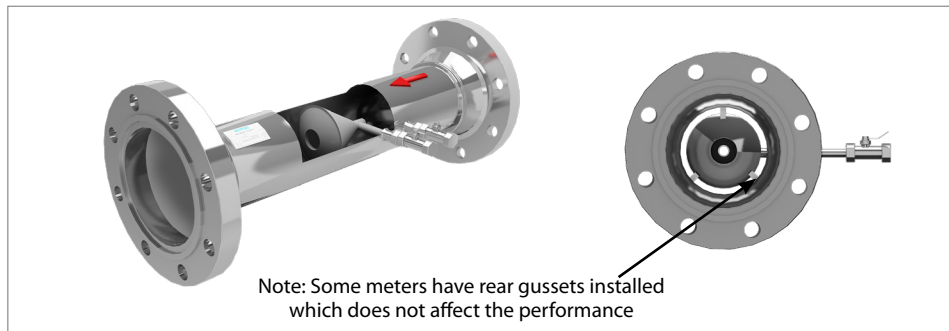

Fig 4: Valve Connections

Valve Manifolds

A 3-way or 5-way valve manifold isolates the transmitter from the process lines (5-valve manifolds are recommended). They allow the operator to calibrate the transmitter without removing it from the impulse tubing, drain the transmitter and impulse tubing or vent it to atmosphere. (See Figure 5)

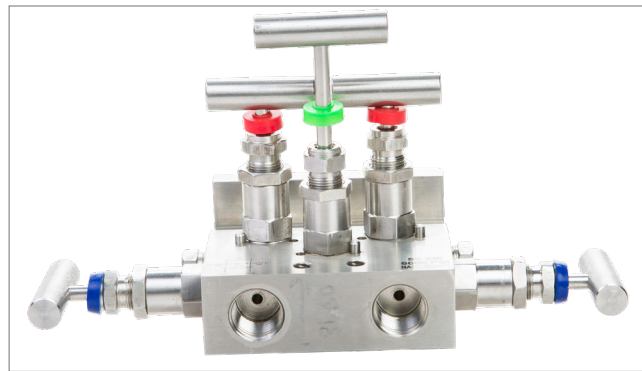

Fig 5: Valve Manifolds

*Note: Valve manifolds must be oriented according to manufacturer's instructions to prevent trapping of air or liquid in the sensing lines and tubing. This can cause an incorrect flow measurement condition.

Impulse Tubing Considerations

Before connecting impulse tubing between the Tek-DP 1620A Cone Meter and its transmitter, consider the following installation advice for optimizing your system's measurement accuracy. "In a well-designed installation, fluids will drain freely from the process lines and gases will vent to the atmosphere".

Tubing Size Selection

Impulse tubing that connects any Tek-DP 1620A Cone Meter tap holes to the transmitter have diameters that change with service conditions. The bore should be no smaller than 1/4" (6 mm) a minimum diameter of 3/8" (10 mm) is recommended to allow for any condensate drainage and also reduce plugging or freezing.

Process Tubing or Sensing Lines

The internal diameter (ID) must not exceed 1" (25 mm). For steam applications, the ID should be in the range 3/8" (10 mm) to 1" (25 mm) depending on meter diameter.

The use of incorrect tubing both diameter and material selection can create a safety risk and the cost incurred to regaining a process system control can be substantial. High reliability is required for flow signals used in process safety management. A minimum tubing ID of 5/8" (16 mm) is recommended for these types of industrial applications were possible. For high temperatures in condensing vapor service, 1" (25 mm) is preferred.

Tubing Lengths and Configurations

For best performance, please try to meet the following recommendations for tubing length and tubing orientation:

- Tubing lengths must be short enough to ensure a high degree of accuracy, and long enough to ensure proper cooling of high-temperature fluids before they reach the transmitter.
- Make sure the installation permits access to impulse tubes, valves, valve manifolds, and transmitters in case of maintenance and also emergency maintenance.
- Limit the number of fittings and avoid long tubing sections, which can impair measurement accuracy and increase the risk of plugging.
- Avoid changes in tubing elevation and fluid temperature if possible. Differences in elevation will cause differences in hydrostatic pressure of liquid columns in process or sensing lines.
- Temperature differences may cause a difference between the density of the fluids in the two sensing lines, which will change the amount of differential pressure measured. Both can result in inaccurate differential pressure measurements. Fasten both process lines together, if possible, to alleviate this type of issue.
- Install process lines so that they slope in only one direction (up or down). If piping must be installed to slope in more than one direction, do not allow more than one bend and install a liquid or gas trap, as applicable. A liquid trap should be installed at the lowest point in a gas service installation. A gas trap should be installed at the highest point in a liquid service installation.

Very High Temperature Applications

Steam vapor can reach 1500°F (815°C), which exceeds the temperature rating of standard DP and pressure transmitters (200°F or 92°C Max). A condensate chamber / vessel can be used to isolate the transmitter from extreme temperature effects. Alternatively, a long tube section can be installed to allow the fluid to cool sufficiently before it reaches the transmitter.

As a general operational guideline when planning tubing lengths for temperature control, run a horizontal tubing orientation where possible, and allow for a temperature drop of 100°F (37.8°C) per foot (305 mm) of tubing.

*Note: This is a rule of thumb guideline, the operator is still responsible for verification that the temperature at the transmitter does not exceed the transmitter's thermal rating including the environmental conditions during operation.

Very Cold Temperatures

During cold temperature installations, thermal insulation and/or "heat tracing" of process lines may be necessary this is required where liquids are present or the possibility of liquid drop out in a gas stream that sustains a freeze temperature to cause the liquid to solidify and block the sensing line. The amount of heat used to prevent these issues must be calculated carefully to also prevent liquids from vaporizing and prevent condensable vapors from producing unwanted condensation dual phase conditions. Fastening process lines together is highly recommended to help keep process lines approximately at the same temperature. Providing temperature-controlled environmental conditions for the transmitter also helps to ensure accurate metering in locations where extreme temperature swings are likely (i.e., offshore platforms, desert installations or arctic circle regions).

Applications

- Tek-DP 1620A Cone Meters are fully capable and designed to work in both unprocessed and processed applications, and are ideal for upstream, midstream and downstream flow measurement applications that present large measurement challenges.
- The Tek-DP 1620A Meter is also available in many different configurations for low-pressure coalbed or seam methane wellhead, High or low pressure separator, wet gas with Tek-DPro Validation Systems steam and other field applications, compressor anti-surge control, and fuel gas as detailed within the company website .

Specifications

Accuracy	±0.5% with Calibration
Repeatability	±0.1% or better
Flow Ranges	10:1 and greater
Standard Beta Ratios	0.45 through 0.85 Special betas available
Instillation Piping Requirements	as per ISO 5167-5. Typically 0-3D upstream and 0-2D downstream is required
Material	Inconel Duplex 304 or 316 Stainless Steel Hastelloy C-276 Carbon Steels Other materials available on request
Line Sizes	2" to 48"
End Connections	Flanged Threaded Hub or weld-end standard Others on request
Performance Verification Testing	ISO 5167-5

Transmitters / Flow Computers

1. Tek-Bar 3110A Explosion Proof Differential Pressure Transmitter
2. Tek-Bar 3800E Multivariable Pressure Transmitter
3. Tek-Bar 3800XH Multivariable Transmitter
4. TEK-FC 8000 Flow Computers



Fig 6: 3110 A Explosion Proof Differential Pressure Transmitter



Fig 7: 3800E Multivariable Pressure Transmitter



Fig 8: 3800XH Multivariable Transmitter



Fig 9: LEK-FC 8000 Flow Computers

Cone Meter Design

- Precision Welded (Fixed Design)

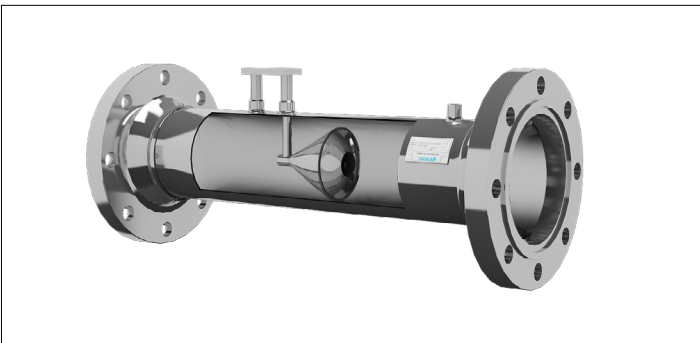

- Field Replaceable Body Top Entry

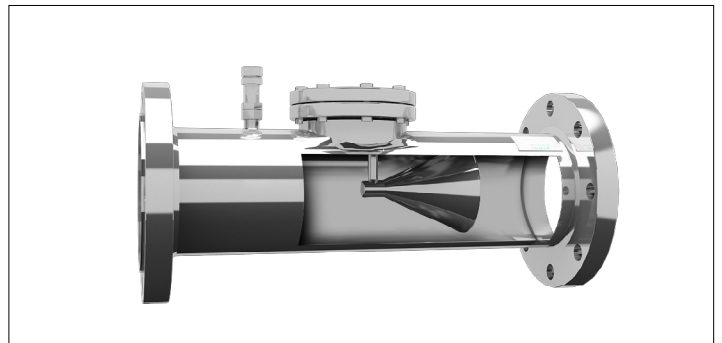

- Field Replaceable Body

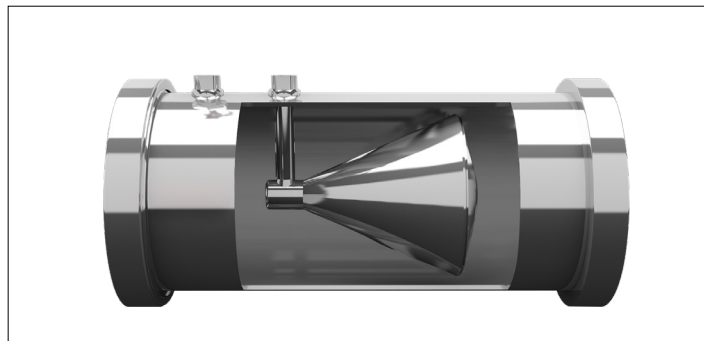

Dimensional Drawings

Beveled End

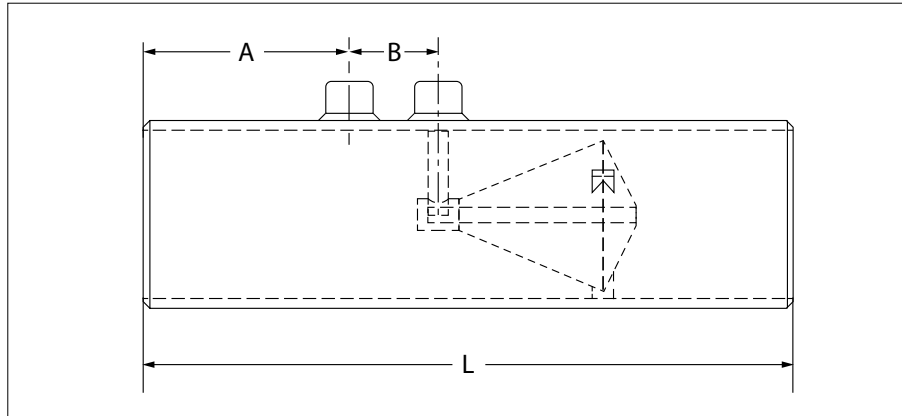

Fig 10: Beveled End

Size in (mm)	L in(mm)	A in (mm)	B in (mm)
2" (50)	9.5" (241)	4.25" (108)	2.13" (53)
3" (80)	12.5" (317)	4.25" (108)	2.13" (53)
4" (100)	15.5" (394)	3.38" (86)	2.13" (53)
6" (150)	19.25" (489)	4.13" (105)	2.13" (53)
8" (200)	23.75" (603)	5.75" (145)	2.13" (53)
10" (250)	29.75" (755)	6.25" (159)	2.13" (53)
12" (300)	35.75" (908)	6.5" (165)	2.13" (53)

Raised-Face Slip on Flange

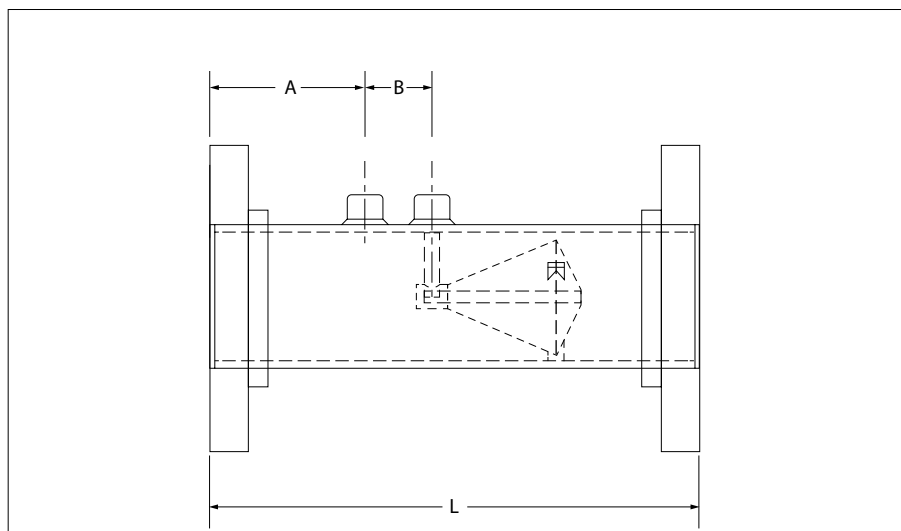

Fig 11: Raised-Face Slip on Flange

***Note:** All TEK-TROL Cone Meters have support gussets (See Dimension Charts on next page)

Size in inches (mm)	150# RF/ SO			300# RF/ SO			600# RF/ SO		
	L in (mm)	A in (mm)	B in (mm)	L in (mm)	A in (mm)	B in (mm)	L in (mm)	A in (mm)	B in (mm)
2" (50)	10" (254)	4.5" (112)	2.13" (53)	10" (254)	4.5" (112)	2.13" (53)	10" (254)	4.5" (112)	2.13" (53)
3" (80)	13" (322)	4.5" (112)	2.13" (53)	13" (322)	4.5" (112)	2.13" (53)	13" (322)	4.5" (112)	2.13" (53)
4" (100)	16" (400)	3.63" (92)	2.13" (53)	16" (400)	3.63" (92)	2.13" (53)	16" (400)	3.63" (92)	2.13" (53)
6" (150)	19.75" (495)	4.38" (111)	2.13" (53)	19.75" (495)	4.38" (111)	2.13" (53)	19.75" (495)	4.38" (111)	2.13" (53)
8" (200)	24" (609)	6" (152.5)	2.13" (53)	24" (609)	6" (152)	2.13" (53)	24" (609)	6" (152)	2.13" (53)
10" (250)	30" (762)	6.5" (165)	2.13" (53)	30" (762)	6.5" (165)	2.13" (53)	30" (762)	6.5" (165)	2.13" (53)
12" (300)	36" (914)	6.75" (171)	2.13" (53)	36" (914)	6.75" (165)	2.13" (53)	36" (914)	6.75" (165)	2.13" (53)

Raised-Face Weld Neck

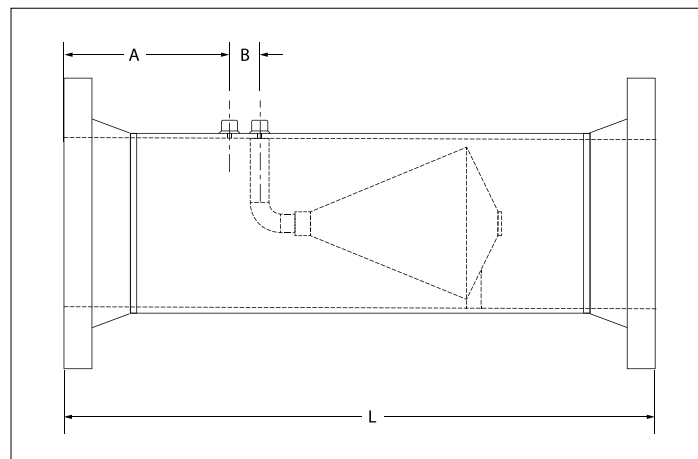

Fig 12: Raised-Face Weld Neck

Size in inches (mm)	150# RF/ SO			300# RF/ SO			600# RF/ SO		
	L in (mm)	A in (mm)	B in (mm)	L in (mm)	A in (mm)	B in (mm)	L in (mm)	A in (mm)	B in (mm)
2" (50)	14.5" (368)	6.75" (171)	2.13" (53)	15" (381)	7" (175)	2.13" (53)	15.75" (400)	7.5" (185)	2.13" (53)
3" (80)	18" (450)	7" (175)	2.13" (53)	18.75" (470)	7.25" (182)	2.13" (53)	19.5" (487)	7.75" (192)	2.13" (53)
4" (100)	21.5" (537)	6.63" (168)	2.13" (53)	22.5" (565)	6.88" (175)	2.13" (53)	25" (625)	7.13" (181)	2.13" (53)
6" (150)	26.25" (657)	7.63" (194)	2.13" (53)	27" (675)	8.13" (206)	2.13" (53)	29" (725)	9.13" (232)	2.13" (53)
8" (200)	31.5" (800)	9.75" (245)	2.13" (53)	32.25" (819)	10.25" (255)	2.13" (53)	34.5" (876)	11.25" (282)	2.13" (53)
10" (250)	37.5" (952)	10.25" (255)	2.13" (53)	38.75" (984)	10.75" (270)	2.13" (53)	42" (1067)	12.5" (312)	2.13" (53)
12" (300)	44.5" (1130)	11" (272)	2.13" (53)	45.75" (1161)	11.5" (287)	2.13" (53)	48.25" (1225)	12.75" (320)	2.13" (53)

* **Note:** Final dimensions should be confirmed at time of order.

***Note:** Dimensions are subject to vary at time of manufacturing based on final Beta selected. Dimensional drawing with a final engineering sizing sheet will be provided within 1-2 weeks of order acceptance.

Process Connections

1. Flange

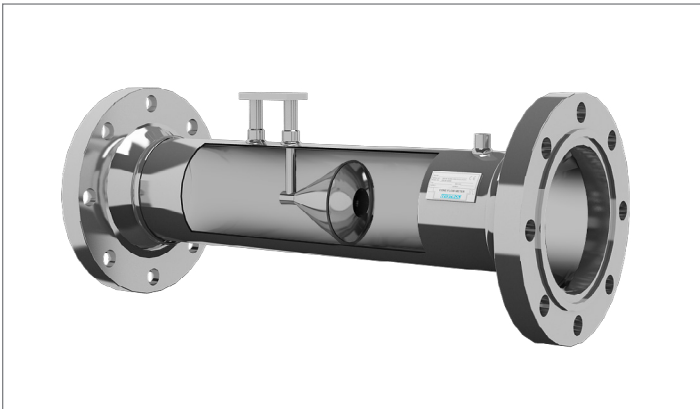

Fig 13: Flange process connection

2. Hub

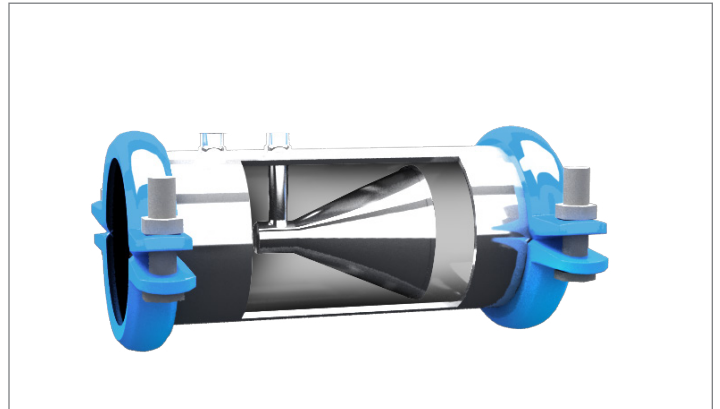

Fig 14: Flange process connection

3. Union

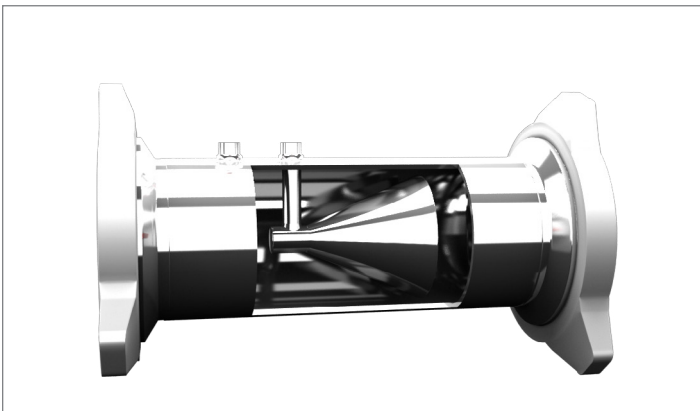

Fig 15: Union process connection

4. Wafer



Fig 16: Wafer process connection

5. Threaded

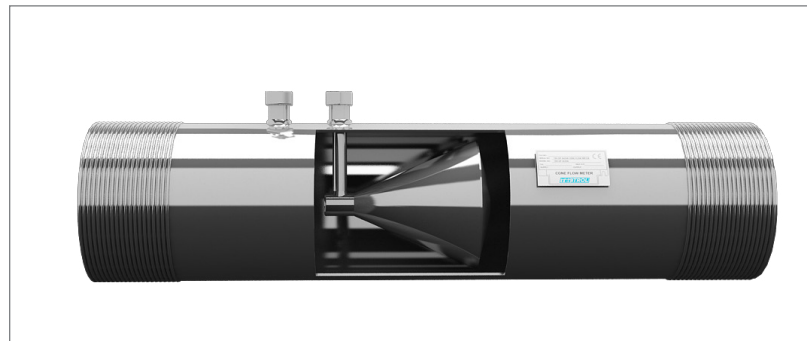

Fig 17: Threaded process connection

Model Chart

Example	Tek-DP 1620A	0050	D	01	A	01	C0	D	00	03	A	XX	A	01	A	MTR	Tek-DP 1620A-0050-D-01-A-01-C0-D-00-03-A-XX-A-01-A
Series	Tek-DP 1620A																Cone Meter
Size		0015 0020 0025 0040 0050 0065 0080 0100 0150 0200 0250 0300 0350 0400 0450 0500 0600 0700 0800 0900 1200															½" (only available for wafer) ¾" (only available for wafer) 1" (only available for wafer) 1.5" 2" 2 ½" 3" 4" 6" 8" 10" 12" 14" 16" 18" 20" 24" 28" 32" 36" 48"
Meter Body			A B C D E F G H I X														Carbon Steel (Standard) Low Temp CS 304L SS 316L SS (Standard) Duplex 2205 Duplex 2507 Chromemoly CrMo P11 Chromemoly CrMo P22 Inconel Cladding Special
Pipe Schedule				01 02 03 04 05 06 07 08 09 10 11 12 13 XX													STD (Standard Pipe Schedule) 10S 10 20 30 40S 40 80S 80 120 160 Extra Strong XX Strong Special

Pressure Tap Style													3000psi NPT 6000psi NPT 3000psi Socket 6000psi Socket Flanged - Direct Mount Hubs Valves Special
Beta													01 02 03 04 05 06 07 XX 0.45 0.50 0.55 0.60 0.65 0.70 0.75 Special
Additional Meter Taps (D/S)													A B C X None Temperature Tap (3D) Validation/Diagnostic Tap (6D) Special
Flow Transmitters / Computers													01 02 03 04 05 06 XX None (Customer Supplied) Tek-Bar 3110 (Liquids) - Smart DP Tek-Bar 3800 (MVT Steam & Compressed Gases) Tek-FC 8000 (Natural Gas - Flow Computer) TekValsys DPRO (Insitu Flow Validation) TekValsys DPRO WFGM (Wet Gas) Special
Calibration													A B C D X Dry (ISO 5167) Water Air Multiphase Special
Options													MTR Material Test Report EN3.1 MC Material Cert EN2.1 PMI Positive Material Identification (NDE) COC Certificate of Conformity HYD Hydro Test XRT X-Ray DPT Dye Penetrant MPT Magnetic Particle Testing O2C O2 Cleaned TAG SS Tag Plate UMR Upstream Meter Run - 1pc DMR Downstream Meter Run - 2 pc FMR Meter Run with Flow Conditioner Plate - 2 pc CDE Certified Drawing Electronic (As Built) MRB Manufacturing Record Book DFT Dry Film Thickness - Custom Paint Spec CPC Custom Product Code

Popular Models

MODEL NO.	DESCRIPTION
150# ANSI Raised Face Slip on Flanges (Stainless Steel)	
1620A-0050-D-01-A-01-C0-D-00-03-A-XX-A-01-A	2" Cone Meter, 316SS, Direct Mount
1620A-0080-D-01-A-01-C0-D-00-03-A-XX-A-01-A	3" Cone Meter, 316SS, Direct Mount
1620A-0100-D-01-A-01-C0-D-00-03-A-XX-A-01-A	4" Cone Meter, 316SS, Direct Mount
1620A-0150-D-01-A-01-C0-D-00-03-A-XX-A-01-A	6" Cone Meter, 316SS, Direct Mount
300# ANSI Raised Face Weld Neck Flanges (Stainless Steel)	
1620A-0050-D-01-B-02-C0-D-00-03-A-XX-A-01-A	2" Cone Meter, 316SS, Direct Mount
1620A-0080-D-01-B-02-C0-D-00-03-A-XX-A-01-A	3" Cone Meter, 316SS, Direct Mount
1620A-0100-D-01-B-02-C0-D-00-03-A-XX-A-01-A	4" Cone Meter, 316SS, Direct Mount
1620A-0150-D-01-B-02-C0-D-00-03-A-XX-A-01-A	6" Cone Meter, 316SS, Direct Mount
600# ANSI Raised Face Weld Neck Flanges (Stainless Steel)	
1620A-0050-D-09-B-03-C0-D-00-03-A-XX-A-01-A	2" Cone Meter, 316SS, Direct Mount
1620A-0080-D-09-B-03-C0-D-00-03-A-XX-A-01-A	3" Cone Meter, 316SS, Direct Mount
1620A-0100-D-09-B-03-C0-D-00-03-A-XX-A-01-A	4" Cone Meter, 316SS, Direct Mount
1620A-0150-D-09-B-03-C0-D-00-03-A-XX-A-01-A	6" Cone Meter, 316SS, Direct Mount
150# ANSI Raised Face Slip on Flanges (Carbon Steel)	
1620A-0050-A-01-A-01-C0-D-00-03-A-XX-A-01-A	2" Cone Meter, CS, Direct Mount
1620A-0080-A-01-A-01-C0-D-00-03-A-XX-A-01-A	3" Cone Meter, CS, Direct Mount
1620A-0100-A-01-A-01-C0-D-00-03-A-XX-A-01-A	4" Cone Meter, CS, Direct Mount
1620A-0150-A-01-A-01-C0-D-00-03-A-XX-A-01-A	6" Cone Meter, CS, Direct Mount
300# ANSI Raised Face Weld Neck Flanges (Carbon Steel)	
1620A-0050-A-01-B-02-C0-D-00-03-A-XX-A-01-A	2" Cone Meter, CS, Direct Mount
1620A-0080-A-01-B-02-C0-D-00-03-A-XX-A-01-A	3" Cone Meter, CS, Direct Mount
1620A-0100-A-01-B-02-C0-D-00-03-A-XX-A-01-A	4" Cone Meter, CS, Direct Mount
1620A-0150-A-01-B-02-C0-D-00-03-A-XX-A-01-A	6" Cone Meter, CS, Direct Mount
600# ANSI Raised Face Weld Neck Flanges (Carbon Steel)	
1620A-0050-D-09-B-03-C0-D-00-03-A-XX-A-01-A	2" Cone Meter, CS, Direct Mount
1620A-0080-D-09-B-03-C0-D-00-03-A-XX-A-01-A	3" Cone Meter, CS, Direct Mount
1620A-0100-D-09-B-03-C0-D-00-03-A-XX-A-01-A	4" Cone Meter, CS, Direct Mount
1620A-0150-D-09-B-03-C0-D-00-03-A-XX-A-01-A	6" Cone Meter, CS, Direct Mount