

CVS Type 67AFR Filter Regulator

Introduction

This CVS Controls product manual includes instructions for the installation, adjustment, maintenance and parts ordering of the CVS Type 67AFR Filter Regulator.

All CVS Controls equipment should be installed, operated and maintained by qualified personnel. If you have any questions regarding this equipment, contact your CVS Controls representative.

Ensure that the label of the control spring range is updated to reflect any changes in field equipment, materials, service conditions or pressure settings.

If any venting occurs or a leak develops in the pressure system this indicates that service is required. Failure to remove the regulator from service for immediate maintenance may cause a hazardous situation.

These regulators are often shipped installed on other equipment. Information on that equipment will be contained in separate manuals.

Description

The CVS Type 67AFR Filter Regulator is a self-operated unit which provides continuous reduced pressures in a variety of applications and service conditions. Common use is as supply pressure regulators for pneumatic instruments.

A cellulose filter is used with the CVS Type 67AFR Filter Regulator and will remove particles greater than 0.0016 inch (0.040 mm) in diameter.

In addition, these regulators contain integral low-capacity relief valves. In this type of construction the valve stem



Figure 1: CVS Type 67AFR Regulator

sits against an orifice in the diaphragm assembly. When downstream pressure increases above the set point, the diaphragm assembly moves off the valve stem and excess pressure is vented through a port hole tapped in the spring case.

Installation

Warning

Do not install any pressure equipment where service conditions exceed the manufacturer's specifications. Over pressuring of regulator may result in leakage, equipment damage or injury. Excessive pressure can cause the pressure-containing parts to burst, or accumulated gas to explode. The CVS Type 67AFR Filter Regulator cannot be used with hazardous gas unless vented to a safe area.

Specifications

Body Size and End Connection Style		1/4-inch NPT screwed
Maximum Allowable Inlet Pressure		250 psig (17 bar)
Outlet Pressure Ranges		3 to 100 psig (0.21 to 6.9 bar) available in four ranges. Refer to Parts List Key 5
Maximum Emergency Outlet Pressure		50 psig (3.4 bar) over outlet pressure setting, or 110 psig (7.6 bar), whichever is greater
Pressure Registration		Internal
Material Temperature Capabilities	Standard Elastomers	-29 to 66°C (-20 to 150°F)
	High Temperature Elastomers	-18 to 188°C (0 to 350°F)

Installation continued

As with many regulators, the outlet pressure rating on the CVS Type 67AFR Filter Regulator is lower than the inlet pressure rating. If it is possible for the actual inlet pressure to exceed the regulator outlet pressure setting or the pressure ratings of any downstream equipment, downstream overpressure protection is required. The low-capacity internal relief feature of the CVS 67AFR provides some limited downstream overpressure protection but should not be relied upon to completely safeguard against overpressure.

Debris in the service line or other external conditions may cause damage to the regulator even while it is operating within normal set pressure ratings. Regular inspection should be scheduled in addition to inspections after any overpressure condition.

Note

If the regulator has been installed on another unit prior to shipping, perform the installation according to the instruction manual for that unit.

For CVS Type 67AFR regulators shipped separately, check the regulator, tubing and piping for damage. Remove any foreign material. Install the regulator ensuring that flow is from the IN to the OUT as marked on the regulator body. Refer to Figure 2 for cutout dimensions for a panel mounted regulator.

To use the unit in regulator shutdown, properly vent the regulator inlet and outlet pressures by installing upstream and downstream vent valves or providing some alternate means of properly venting the inlet and outlet pressures.

For optimum filter drainage, position the drain valve (Key 11) at the lowest possible point on the filter cap (Key 9). Prevent plugging of the spring case vent and keep the spring case from collecting moisture, corrosive chemicals or other materials by orienting the vent to the lowest possible point on the spring case.

To change the filter/drain orientation, rotate the filter cap with regards to the regulator body. Change the spring case/vent orientation by rotating the spring case in relation to the regulator body.

Any CVS type 67 AFR Filter Regulator with a tapped spring case can be vented remotely by installing tubing or piping into the 1/4-inch NPT vent tapping. Install a screened vent cap in the end of the tubing or piping to prevent clogging.

If using piping, apply pipe compound to threads then proceed with making the connections. First install the piping or tubing into the 1/4-inch NPT inlet connection. Unless the outlet connection has been made at the factory to another unit, install the piping or tubing to the outlet connection.

Warning

Never adjust the control spring to produce pressure beyond its highest outlet pressure range. Over pressuring the spring can cause bursting of pressure containing parts, or explosion of accumulated gas. If the range of the control spring does not reach the desired outlet pressure install a spring with the proper range according to the maintenance section.

Installation continued

CVS Controls sets each regulator for the pressure setting specified at the time of ordering. If no setting was indicated, the outlet pressure will be set at the midrange of the control spring.

Startup

Refer to Figure 2 for Key Numbers.

After completion of installation and adjustment of downstream equipment, introduce pressure to the unit by slowly opening the upstream and downstream shutoff valves. During any startup or adjustment, monitor the adjustment using pressure gauges. Outlet pressure of the regulator can be monitored using a gauge installed at a downstream position, including the supply pressure gauges of a pneumatic instrument where the regulator is providing reduced pressure. If the regulator has a tapped side outlet a gauge (Key 20, not shown) may be installed for monitoring. If the regulator has no gauge but the side outlet has been tapped and plugged, the side plug may be removed and a temporary gauge installed.

During the adjustment procedure monitor the outlet pressure with a gauge, if outlet pressure is necessary; adjust the standard CVS Type 67AFR regulator by loosening the locknut (Key 2) and turning the adjusting screw or handwheel (Key 1). Clockwise adjustment will increase the outlet pressure setting, and counter-clockwise adjustment will decrease the outlet pressure setting. On some regulators, a closing cap (Not shown) will have to be removed prior to adjustment and replaced afterward. Locknuts or handwheels are not used on panel-mounting regulators.

Shutdown

1. Close the nearest upstream shutoff valve.
2. Close the nearest downstream shutoff valve.
3. Open the downstream vent valve and release the pressure.
4. Open the upstream vent valve and release the pressure.

5. If vent valves have not been installed, safely bleed off inlet and outlet pressure and ensure that the regulator contains no pressure.

Maintenance

Due to normal wear, internal parts must be inspected and replaced regularly depending upon the severity of service conditions. High pressure drops and large amounts of impurities in the flow stream accelerate wear on regulator and valve parts.

To empty moisture from the filter cap (Key 9), by periodically open the drain valve (Key 11).

Warning

Prior to performing maintenance operations, isolate the unit from the pressure system and vent all internal pressure.

Perform the following procedures when changing the control spring or to inspect, clean or replace any other parts.

Note

If the regulator has been installed with sufficient clearance, the body assembly may remain mounted on other equipment or in a line or panel during maintenance.

To access the diaphragm assembly (Key 12), control spring (Key 5) or upper spring seat (Key 3):

1. Loosen the locknut (Key 2, if used) and turn the adjusting screw (Key 1) counterclockwise to remove all compression from the spring.
2. Remove the machine screws (Key 18) and separate the body assembly from the spring case (Key 4).
3. Inspect the removed parts and replace if necessary.
4. Ensure the registration (Sensing) hole is free from debris and reassemble.
5. Verify the proper control spring setting according to the "Startup" instructions and remark the control spring label if necessary.

Maintenance continued

To access the valve plug (Key 6) or filter element (Key 15) for replacement or cleaning:

1. Remove the cap screws (Key 18) using a 12-point socket wrench.
2. Remove the filter cap (Key 9) and gasket (Key 14).
3. The following parts may come off with the filter cap, or may be removed individually: retainer (Key 10), filter element (Key 15), valve spring (Key 8), valve spring seat (Key 13) and valve plug and stem (Key 6). Keep all parts together.
4. Inspect all parts and replace if necessary. Ensure the valve plug seating surfaces are clear of debris. If the filter element is dirty it may be cleaned with solvent and blown dry.

Parts Ordering

To help CVS Controls assist you better, include the regulator type number and other important data stamped on the bottom of the filter cap and on the control spring label. Refer to the following parts list when ordering.

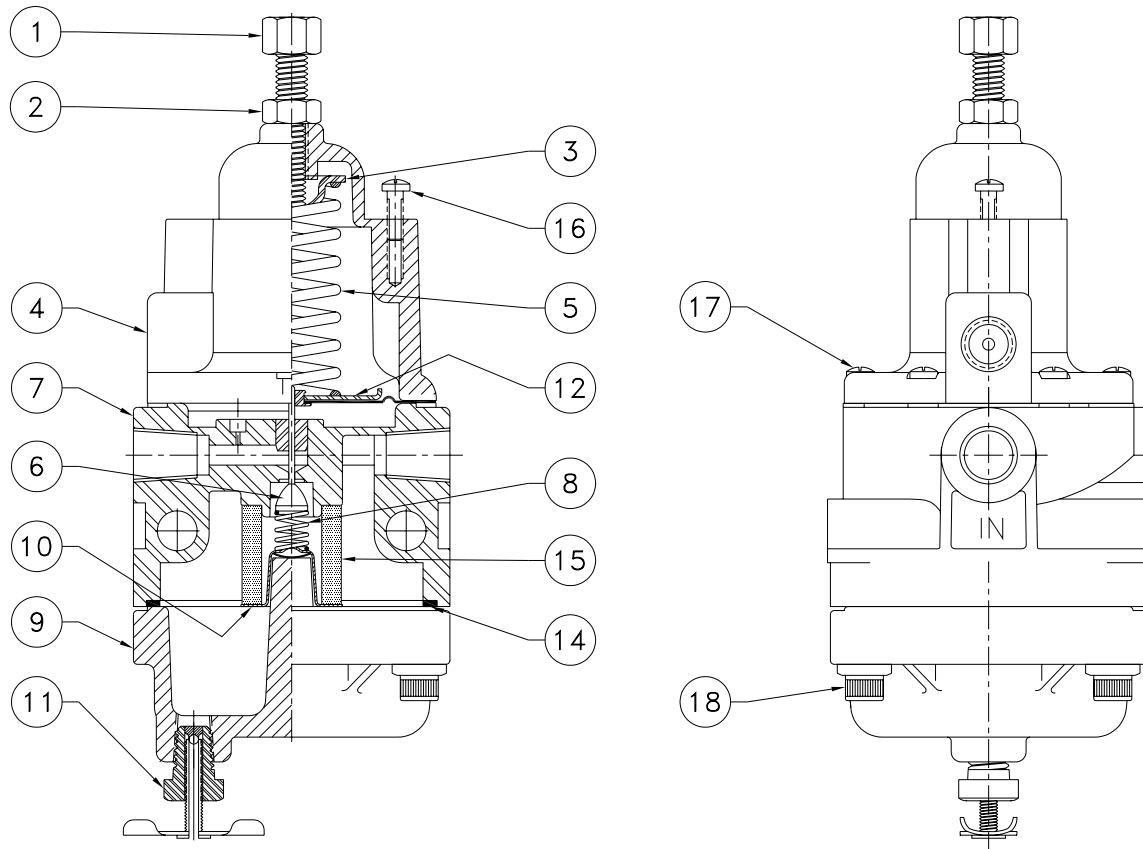

Figure 2: CVS Type 67AFR Regulator

Parts List

Key No.	Description		Part #	
1	Adjusting Screw	Standard: Plated steel	CVS1B798628982	
		Handwheel (Optional)	Standard: Right Hand Thread, Zn	CVS1B7992000A2
			Right Hand Thread, Chrome Pl Steel	CVS1U1715000C2
2	Locknut (not used with panel mounted regulators)		CVS1A946324122	
3	Upper Spring Seat, steel, zinc plated		CVS1B798525062	
4	Spring Case, Panel mounting, vented bonnet		CVS67A0003	
5	Control Spring, plated steel		3 to 20 psig (0.21 to 1.4 bar) range, green	CVS1B986027212
			5 to 35 psig (0.34 to 2.4 bar) range, cadmium	CVS1B788327022
			30 to 60 PSIG (2.1 TO 4.1 bar) range, blue	CVS1B788427022
			35 to 100 psig (2.4 to 6.9 bar) range, red	CVS1K748527202
*6	Valve Plug and Stem		Nitrile with Brass stem CVS1D5604000B2	
7	Body	2 Outlets	Aluminum with SST bushing CVS15A5969X042	
8	Valve Plug Spring, Inconel		CVS1C127337022	
9	Filter Cap, aluminum		CVS35A5963X012	
*10	Retainer, plated steel (consists of Spring Washer, plated Stl)		CVS15A5970X012	
11	Drain Valve, Brass		CVS1K4189	
*12	Diaphragm Assembly (includes pl steel diaphragm plate)	Nitrile w/Brass relief valve seat CVS19A7667		
13	Non Relief Diaphragm Assembly (Not Shown)		CVS1B7980	
14	Gasket, neoprene		CVS1C128003012	
*15	Filter Element	Plain cellulose CVS1F257706992		
16	Mounting Screw, SST (2 required)		CVS1C276028992	
17	Machine Screw, SST (6 required)		CVS1B783928982	
*18	Cap Screw, SST (4 required)		CVS1K764724052	
19	Pipe Plug (use only w/2-outlet body, not shown)		Hex head, steel, Cd pl	CVS1D754828982
			Socket head, steel	CVS1C333528992
20	Pressure Gauge (not shown)		0 to 30 psig	CVS1J946099012
			0 to 60 psig	CVS1J975299012
			0 to 100 psig	CVS1J975399012
			0 to 160 psig	CVS1J975499012

* Recommended Spare Part

Notes

Notes



Head Office
3900 – 101 Street
Edmonton, Alberta, Canada T6E 0A5
Office: (780) 437-3055
Fax: (780) 436-5461

Calgary Sales Office
3516 114 Avenue SE
Calgary, Alberta, Canada T2Z 3V6
Office: (403) 250-1416
Fax: (403) 291-9487

Website: www.cvs-controls.com E-Mail: info@cvs-controls.com